

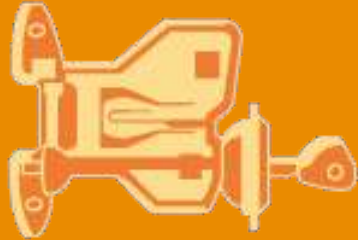

Strength  
Through  
Technology®

**Multimatic**

# Multimatic



Strength  
Through  
Technology®

**Multimatic**

Hinge Systems Group

## Multimatic Tailgate Step for Ingress/Egress

*September 2008*

## Tailgate Step for Ingress/Egress

**Overview**



**Design Features**

**Summary**



## Overview

**Allows easy access to the Pickup Box cargo**



## Overview

### Simple intuitive operation



## Tailgate Step for Ingress/Egress---Operation

### STOWED POSITION

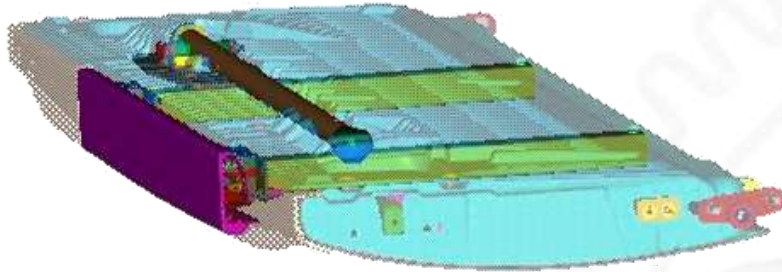

- Fully integrated into the Tail Gate
- Step and Handle are locked into the gate when not used



# Tailgate Step for Ingress/Egress---Operation

## STEP RELEASE

Release Cover  
to Unlatch

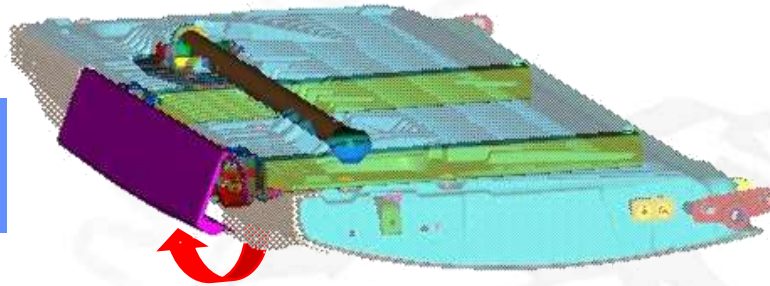

Pull Step  
out of Gate  
to deploy

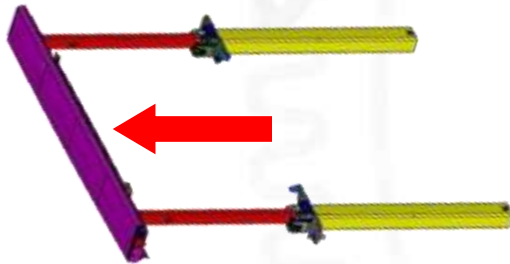

## Tailgate Step for Ingress/Egress---Operation

DEPLOYED  
POSITION

Pull Lever and Lift  
Handle to lock in to  
position

Lower and flip  
out Flip Step

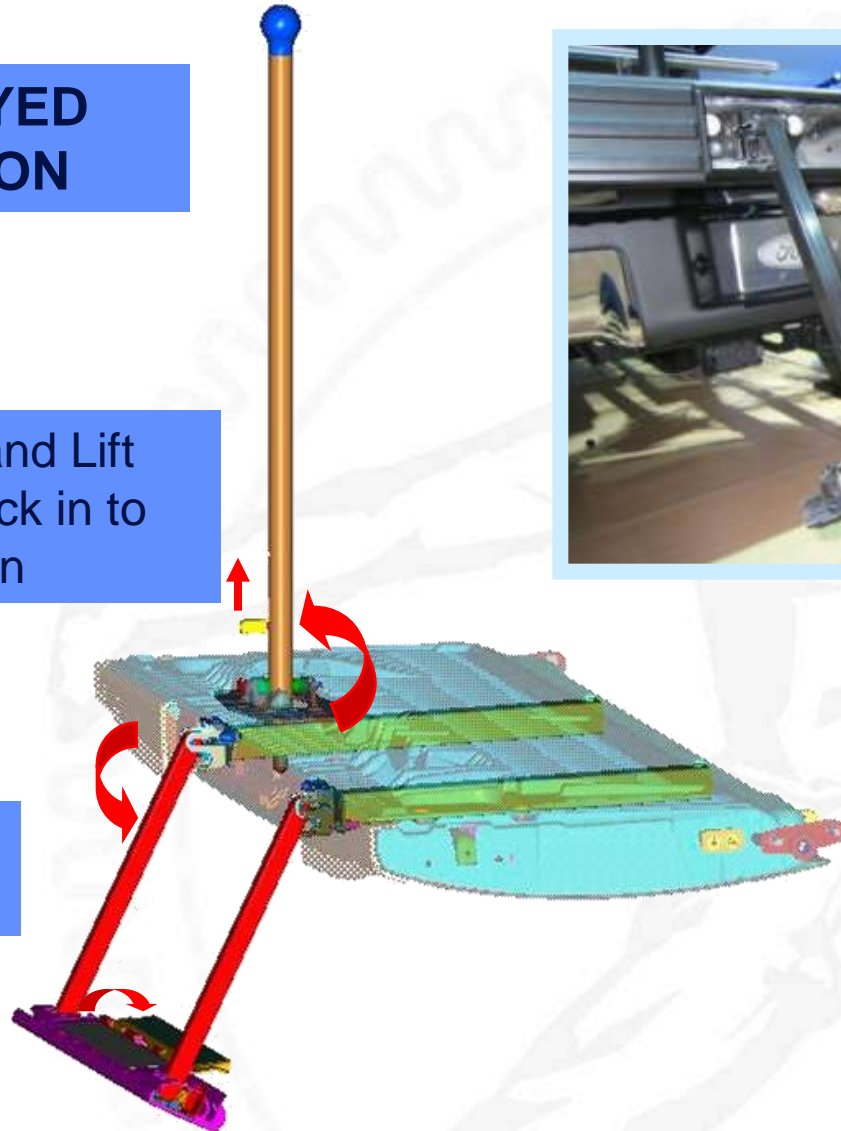

## **Box Access Step**

**Overview**

**Design Features**

**Additional Novel Features**

**Summary**





## Step Guide Details

**Guide Rollers and Leaf Springs ensure smooth and quiet deployment and stowage**

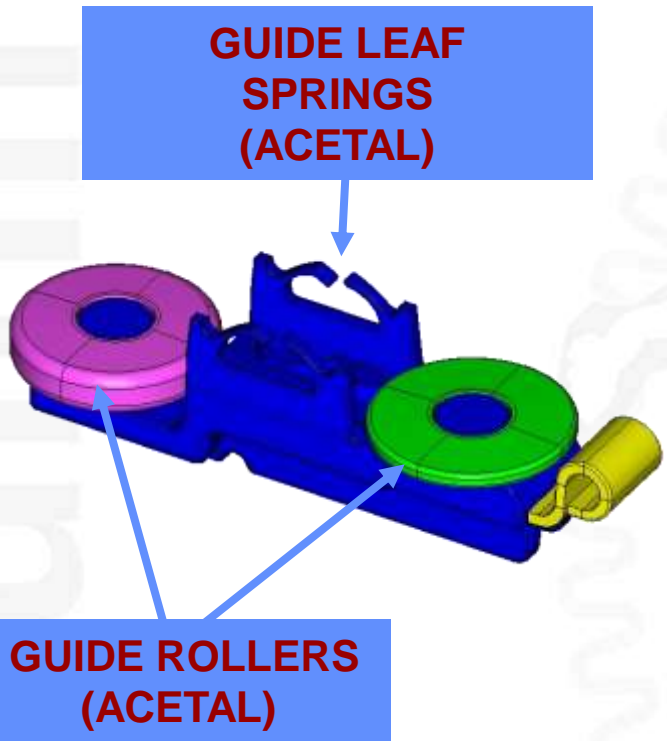

**Stowed Position**

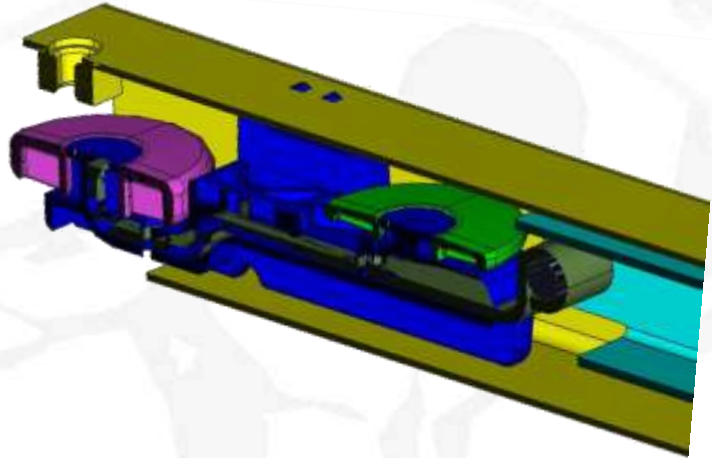

**Deployed Position**

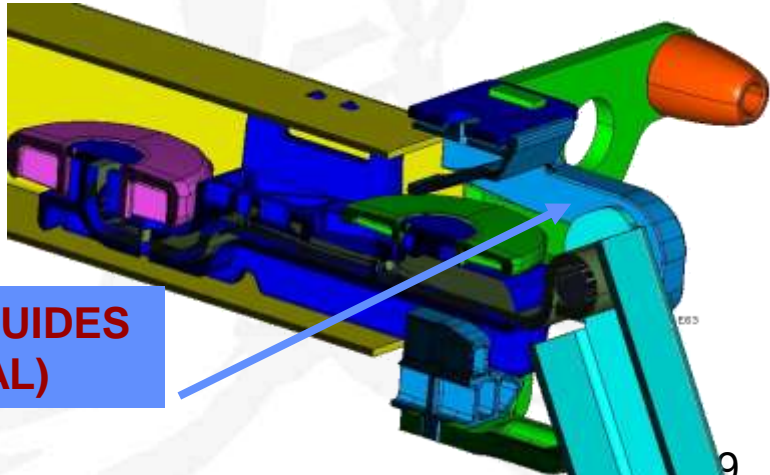

## Flip Step Detail

**Flip out Step provides additional tread surface**

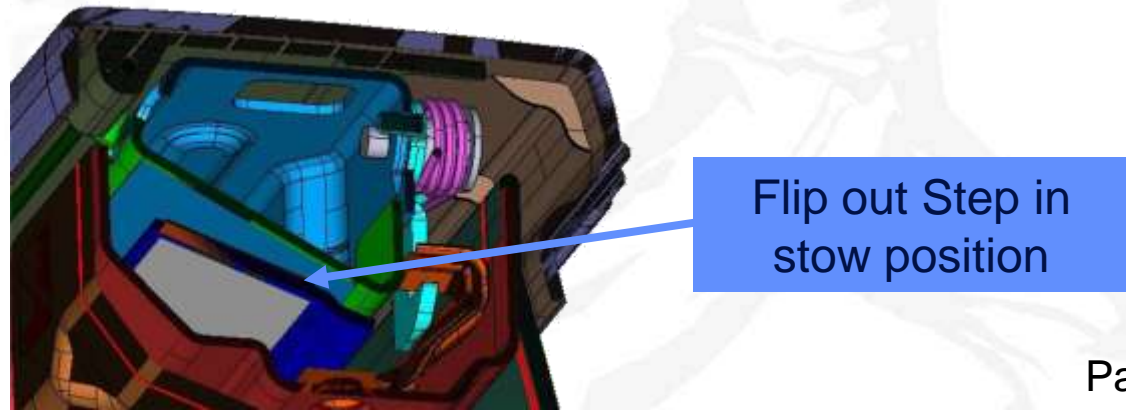
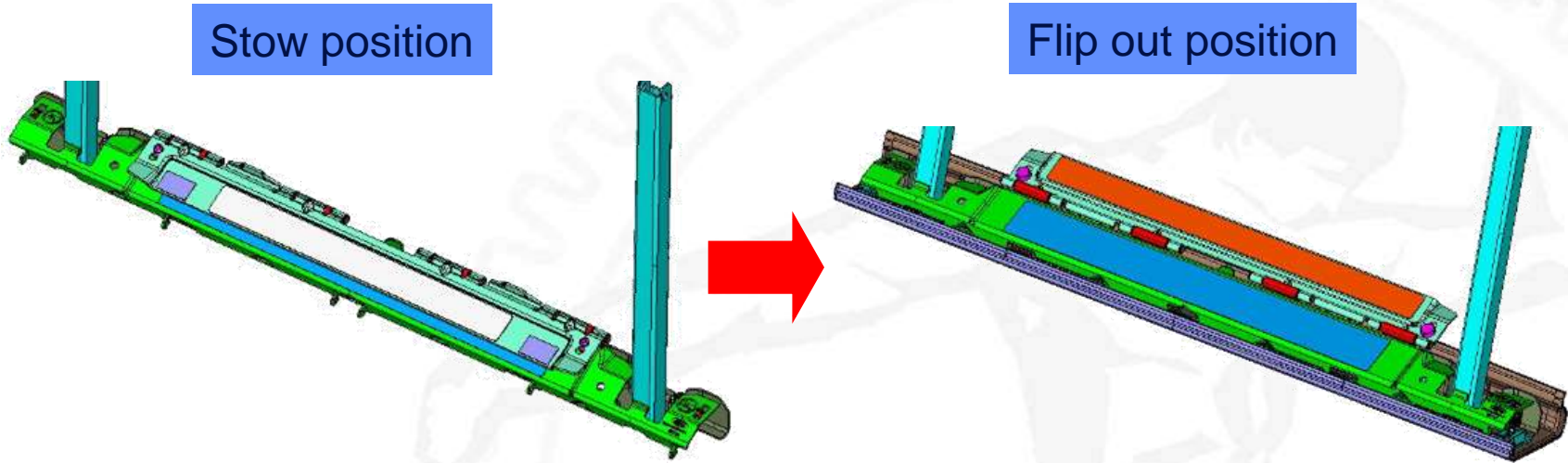

## Step Latch Detail

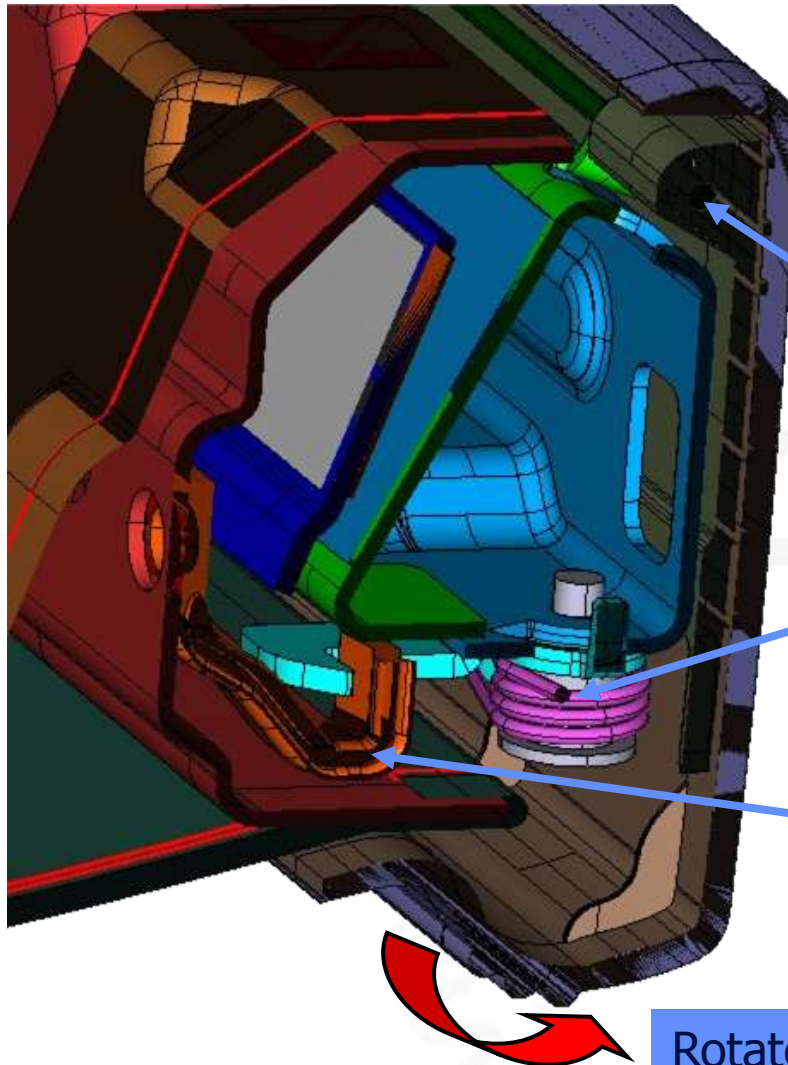

**Stowed Position  
Fully Latched**

**CAP PIVOT**

**Two Piece molding vibration welded  
30% glass filled Polypropylene  
Color matched to the box top moldings**

**LATCH  
MECHANISM**

**STRIKER**

**Rotate End Cap to Release Step**

Strength  
Through  
Technology®

## Grab Handle Details

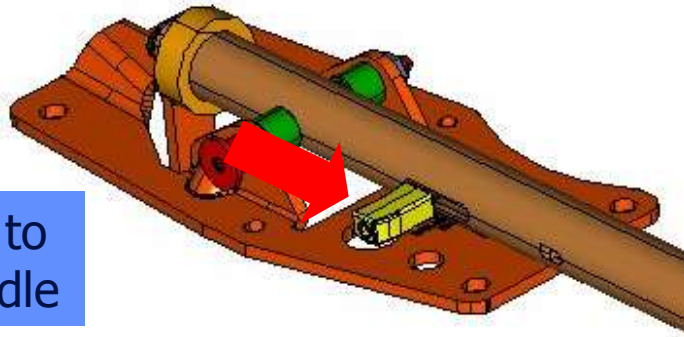

Push Lever to  
release Handle

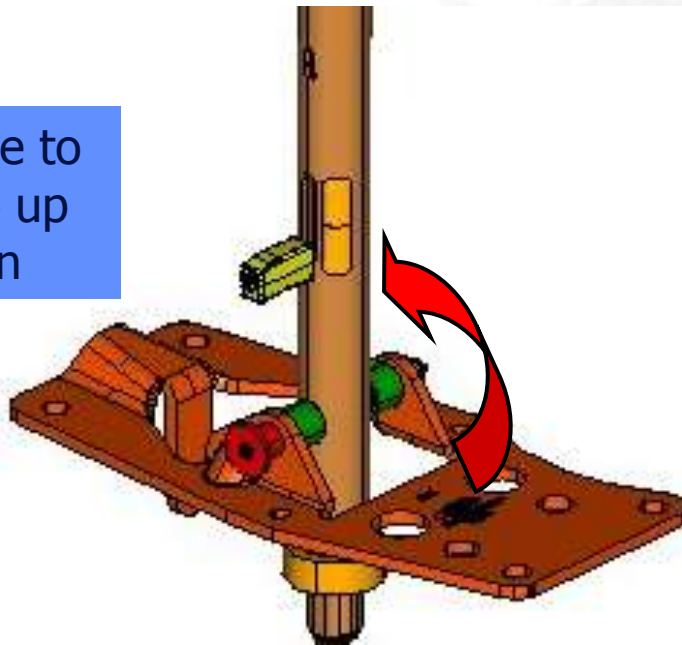

Lift Handle to  
lock in to up  
position

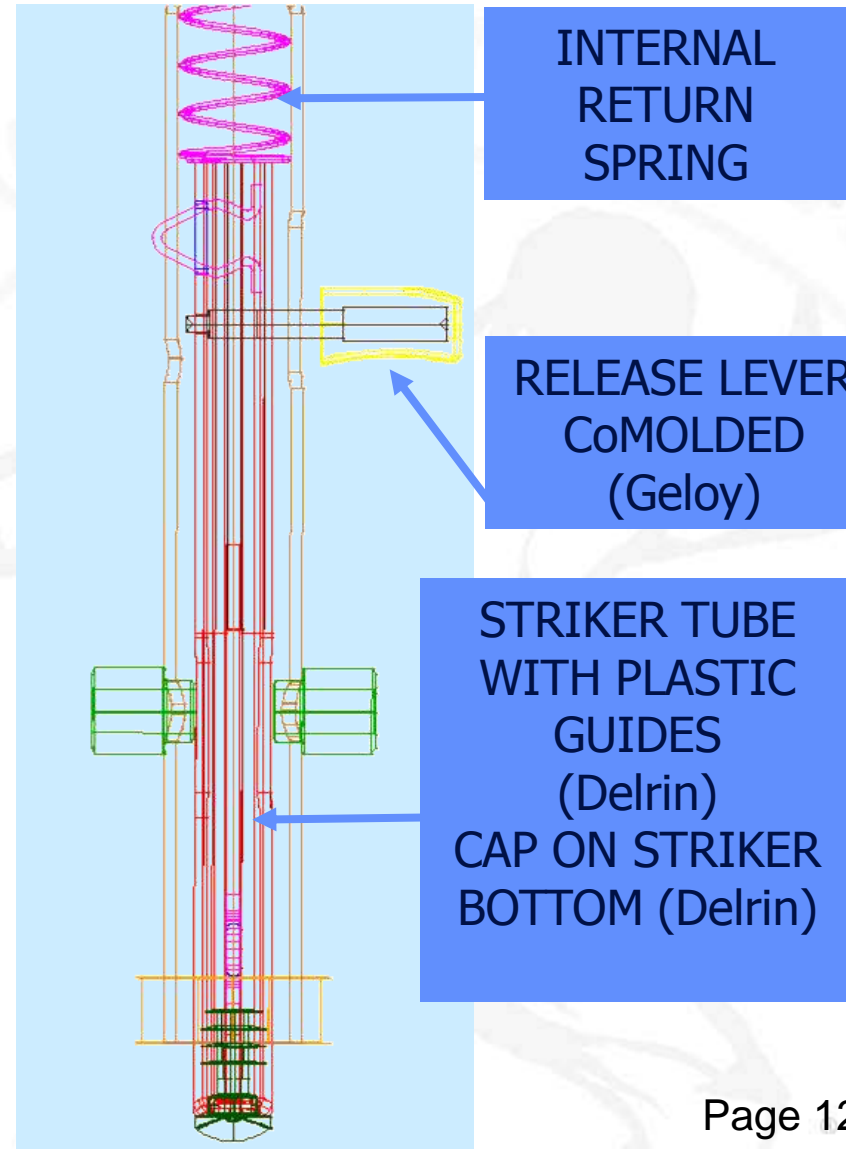

# Stepgate Installation

**Stepgate installation to Tailgate via 6 Bolts.**

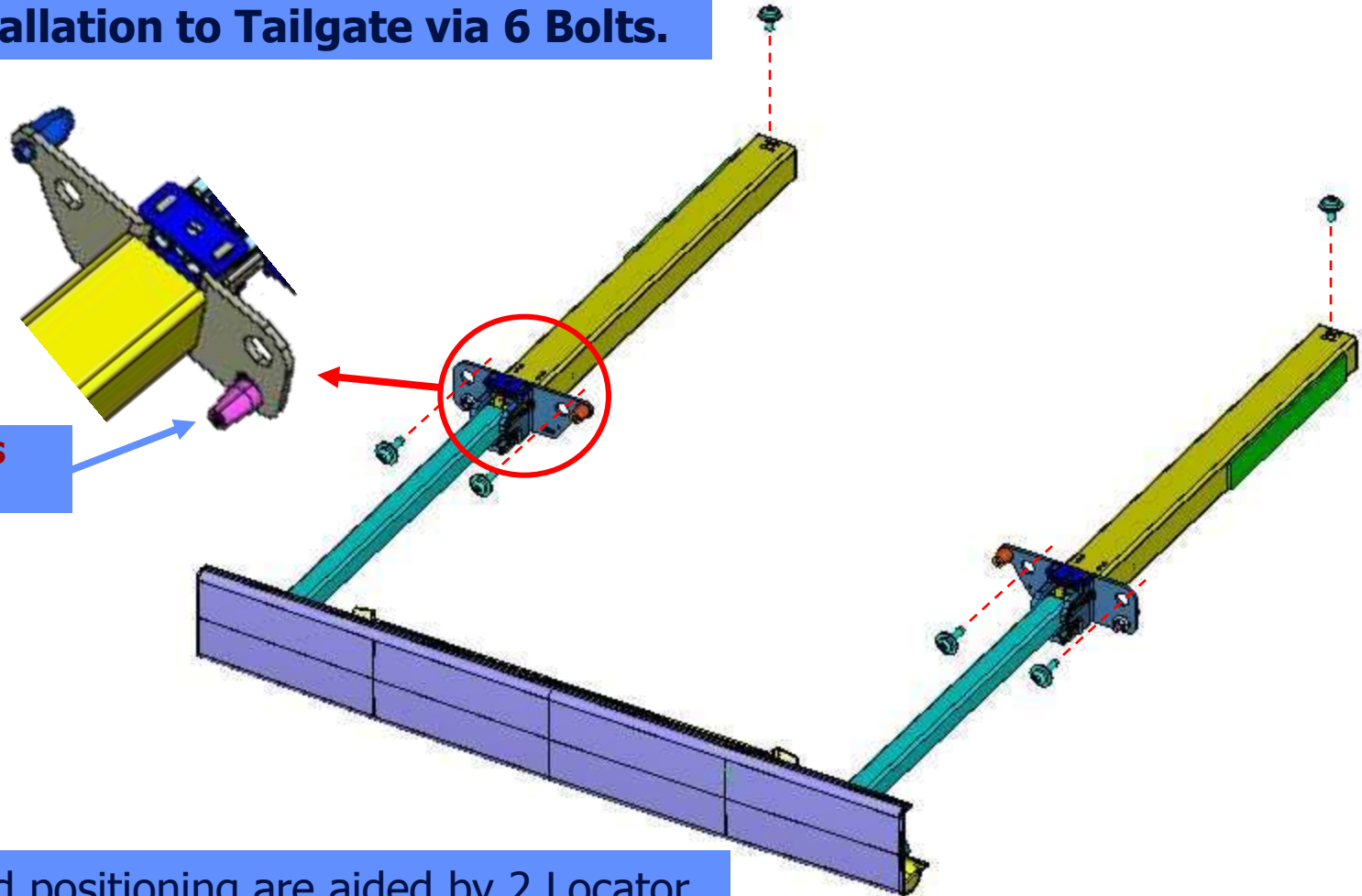

Orientation and positioning are aided by 2 Locator Cones eliminating the need for installation tooling

## Grab Handle Strength

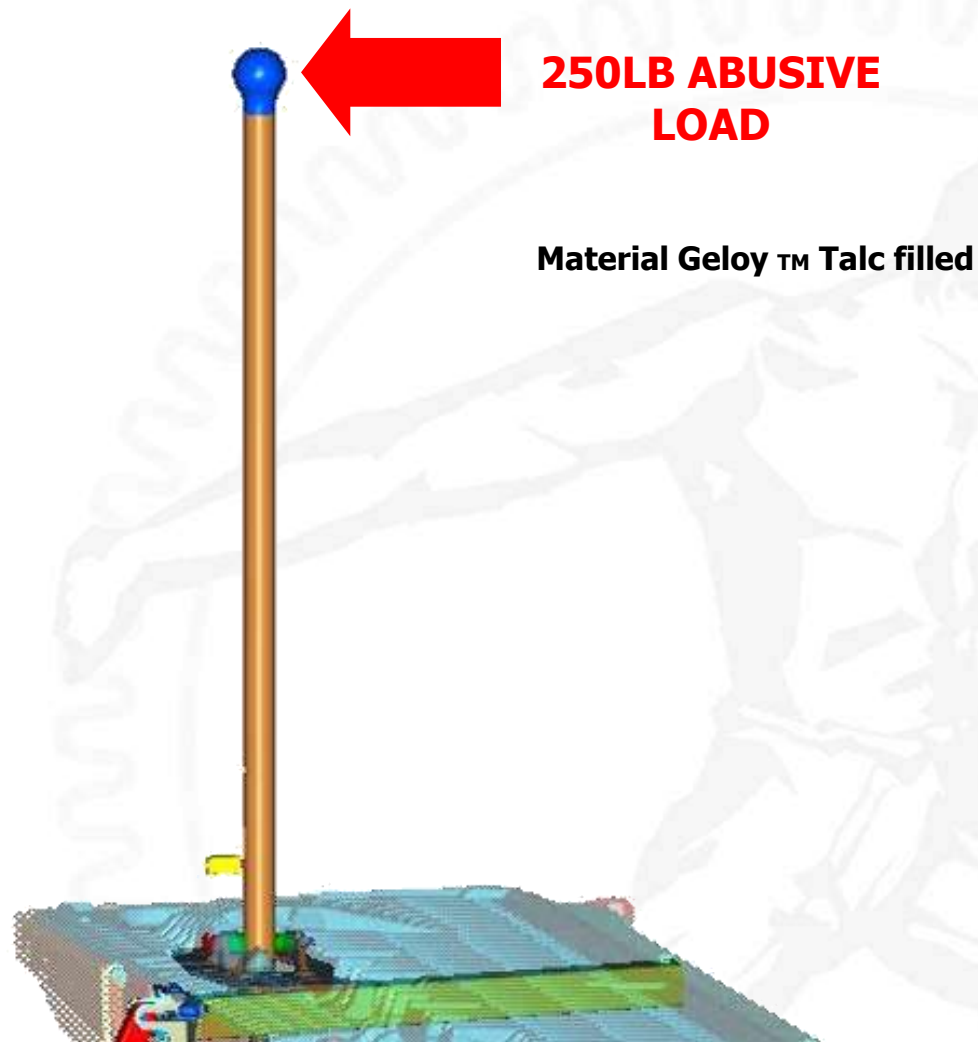

## Box Access Step

**Overview**

**Design Features**

**Summary**

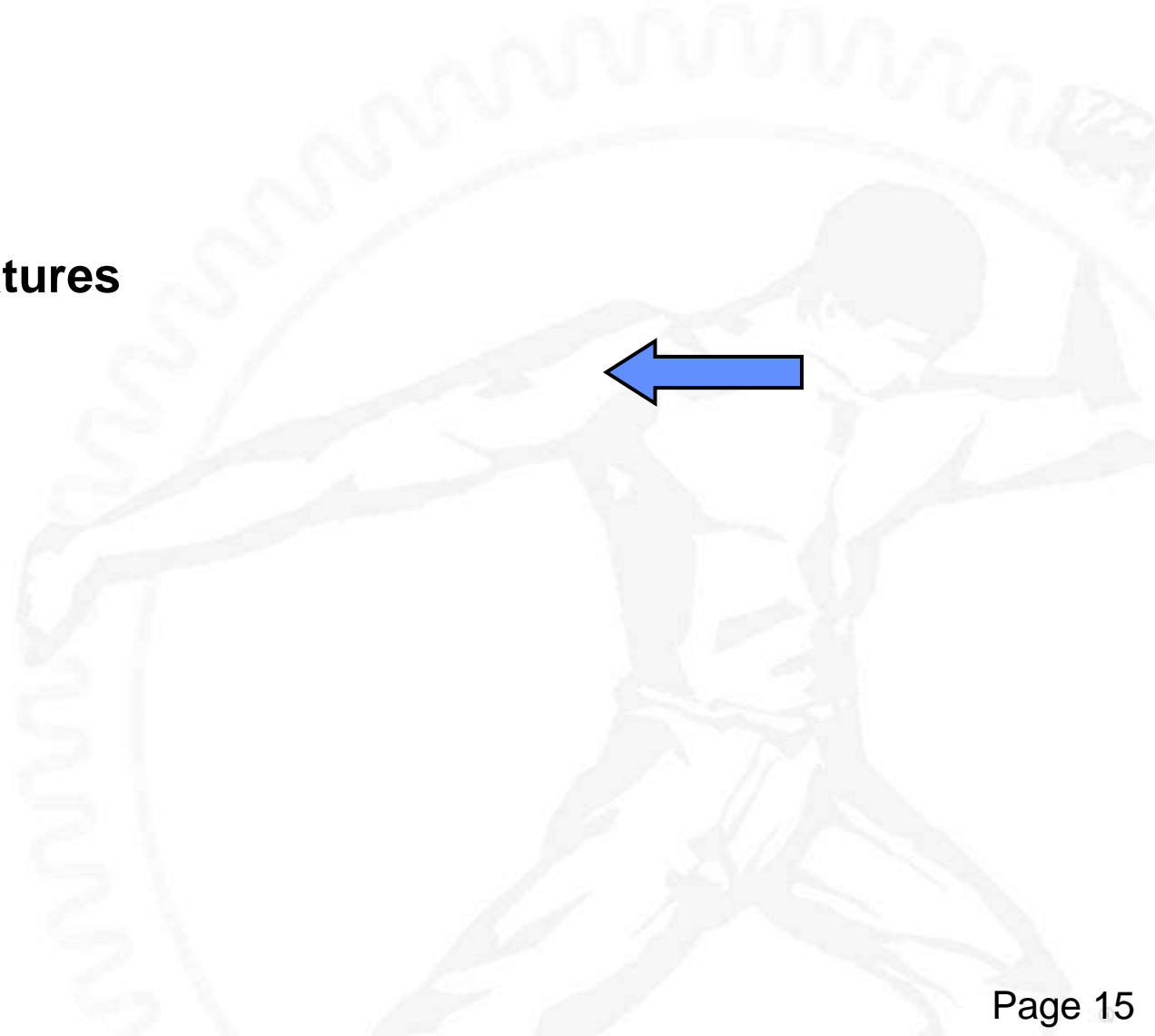

## Stepgate System Summary

### **Allows easy access to the Pickup Box cargo**

- Smooth and easy deployment and stowage operation
- Step and handle stow neatly in the tailgate when not in use
- Cost reduction opportunities identified for next generation design
- Novel features for next generation design
- Fully tested and production ready
- In production on 2007 Ford Super Duty
- In production on 2008 Ford F-150





---

---

***Thank You!***



Strength  
Through  
Technology®

**Multimatic**

---