



Automotive



 World Class Tooling Since 1962

Aerospace



Home & Building



Nickel Vapor Deposition (NVD) Shell Tooling & Product Applications

September 2007

**Rob Sheppard, P. Eng
Vice-President**

Weber Manufacturing Technologies Inc.

1

Overview of Weber

Company History

- 1962 Established Weber Manufacturing (Windsor) Limited
- 1967 Relocated to a new building in Midland, Ontario
Established the Weber Tool & Mold Division
- 1989 Established the Nickel Tooling Technology (NTT) Division
- 1991 Sold our first Nickel Shell
- 1998 Built and tested NVD Pilot Plant
- 1999 Designed and Built Large Scale NVD Plant
- 2000 Commissioned the NVD Nickel Division
Produced our first Nickel Shell in February

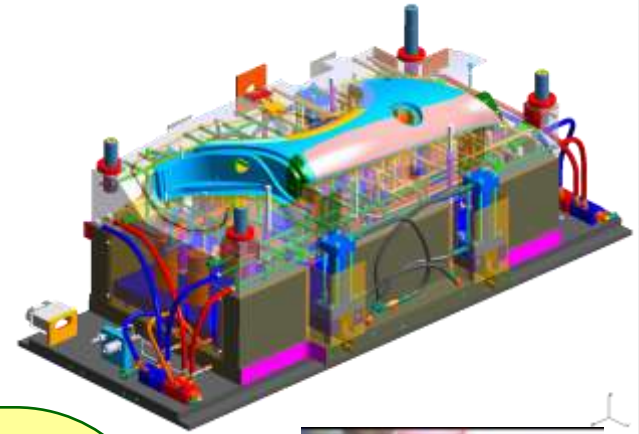

**High Quality, Large Class A
Compression Molds**
NVD Nickel Shells & Molds
Nickel Products



Why Choose Weber

Four key Advantages of Nickel Shell Tooling

1. Solid, stress free nickel shells created by the NVD process are accurately deposited on precision, CNC machined metal mandrels. High accuracy and repeatability from a single, re-usable master.
2. Speed to market: Deposition rates of 0.010inch/hour allow nickel shell tools to get to market ahead quickly. A 5mm thick nickel shell is produced in 20hrs., regardless of size.
3. Highest fidelity replication of authentic surface detail; leather grains, wood grains or engineered textures into high volume production nickel shell tooling.
4. Nickel shell tooling affords conformal heating & cooling designs which support shorter cycle times and uniform mold face temperatures.

NVD NICKEL SHELL

1. Density = 8870 kg/m^3
2. Thermal Expansion = $13.1 \times 10^{-6} \text{ mm/mm } ^\circ\text{C}$
3. Thermal Conductivity = $88 \text{ W / m } ^\circ\text{C}$
4. Hardness = 30-42 Rc
5. Lighter mold (shell), heat and cool quickly
6. Conformal Heating/Cooling = uniform mold face temperature
7. Corrosion resistant
8. Replicates from same CNC machined mandrel

P20 TOOL STEEL

1. Density = 7800 kg/m^3
2. Thermal Expansion = $12.6 \times 10^{-6} \text{ mm/mm } ^\circ\text{C}$
3. Thermal Conductivity = $29 \text{ W / m } ^\circ\text{C}$
4. Hardness = 27-55 Rc
5. Heavy mold (solid block), high thermal inertia
6. Rectilinear Gundrilled Heating/Cooling circuits
7. Not corrosion resistant
8. Each cavity CNC machined

2

Market Approach

Key Market Areas



Automotive



**Home/Building
Products**



Aerospace



3

Markets
Automotive Interiors

Automotive Interiors

- Tooling for all automotive interior components (i.e. Instrument Panels, Gloveboxes, Doors, Armrests, Middle Consoles, etc.). The only exceptions are high pressure thermoplastic injection parts.
- Molds generally consist of NVD nickel shell cavities.
- Parts are “soft touch” or “leather like” with a leather or technical grain.
- Main molding processes employed:
 - Polyurethane (PU) Spray Skin
 - Direct Backfoam (DBF) -> PU Skin & Foam
 - Slush or Cast Skin (PVC, TPO and TPU materials)
 - Reaction Injection Molding (RIM)
 - Vacuum Forming
- Weber NVD advantages in this segment:
 - Superior and repeatable grain replication.
 - Excellent mold durability -> 30-42 HRC
 - Fast Process -> 0.25mm/hr
 - Excellent mold release characteristics.
 - Conformal heating/cooling -> faster cycle times.
 - Excellent weldability -> welds like steel.
 - Duplicate shell/mold delivery times -> ~2-4 weeks
 - Accurate -> ~ +/- 0.25mm



Customers – OEM, Tier 1 & 2



Mercedes-Benz



DaimlerChrysler Programs



M-CLASS (IP, DOORS, GLOVEBOX & MIDDLE CONSOLE)



SLK (IP, DOORS AND GLOVEBOX)



DaimlerChrysler Programs

IP, GLOVEBOX,
ARMRESTS,
MIDDLE CONSOLE
& COVER PANELS
(COMMON TO
BOTH VEHICLES)



A-CLASS



B-CLASS



GM Programs



**BUICK LACROSSE
DOORS**

**CADILLAC SRX
DOORS**

**CADILLAC STS
IP & DOORS**

Nissan Programs



QUEST IP



ARMADA IP



Automotive Interior Mold Types



DIRECT BACKFOAM IP MOLD BUILD

Direct Backfoam (DBF) Molds



DAIMLERCHRYSLER
INSTRUMENT PANEL



DAIMLERCHRYSLER
DOOR PANELS



Spray Molds

IP LOWER DRIVER MOLD (M-CLASS)



MIDDLE CONSOLE MOLD (R-CLASS)



FRONT ARMREST MOLD (A-CLASS)

Slush Molds



HOT OIL DOOR MOLD (BUICK LACROSSE)



HOT AIR COCKPIT MOLD (RANGE ROVER)

RIM Molds

SPE PLASTICS AWARD



RIM PU OVERMOLD
(BMW 6-SERIES
CABRIOLET COVER
PANEL)



RIM SKIN
INJECTION
MOLD
(RANGE ROVER
IP TOPPER)



NVD TEXTURED NICKEL SHELL PROCESS FLOW

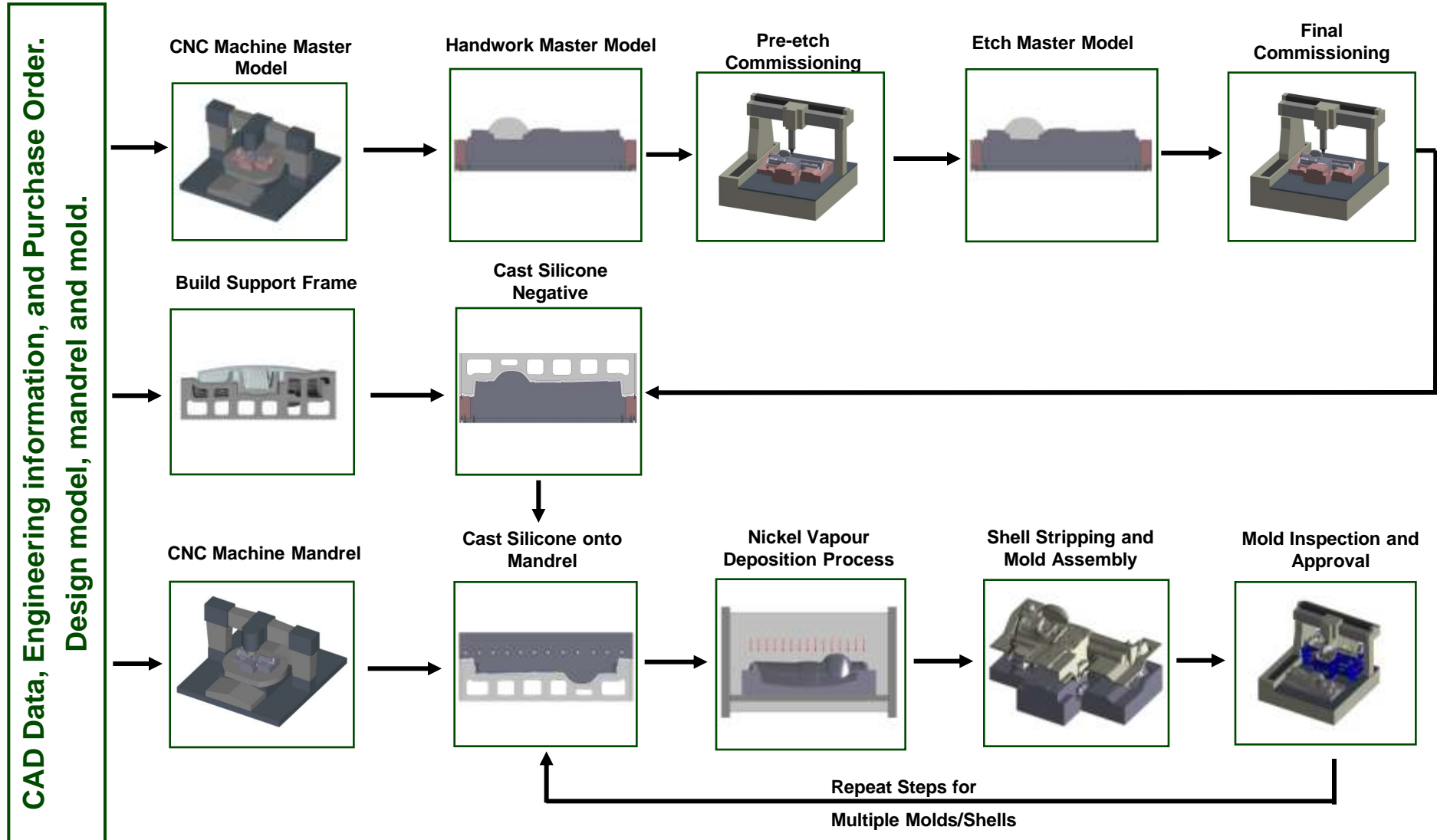

CNC MACHINING OF STEEL MASTER MODEL

- Master models are machined from large blocks of P20 tool steel on precision 5-Axis CNC machines.

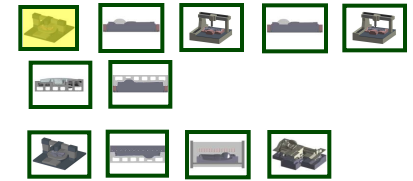

ETCHED STEEL MASTER MODEL

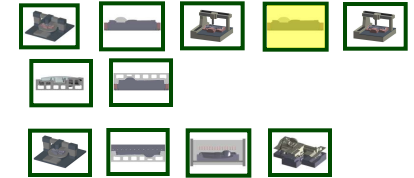

- Steel master models are packaged and shipped to the etching company selected by the customer.
- The positive part texture is acid etched into the model.
- The model is commissioned by the OEM and the customer.
- Master models are returned.



INSPECTION AND FINAL COMMISSIONING OF MASTER MODEL

- Master models are re-inspected after etching.
- Model is now ready for patented replication process to prepare mandrel for NVD.

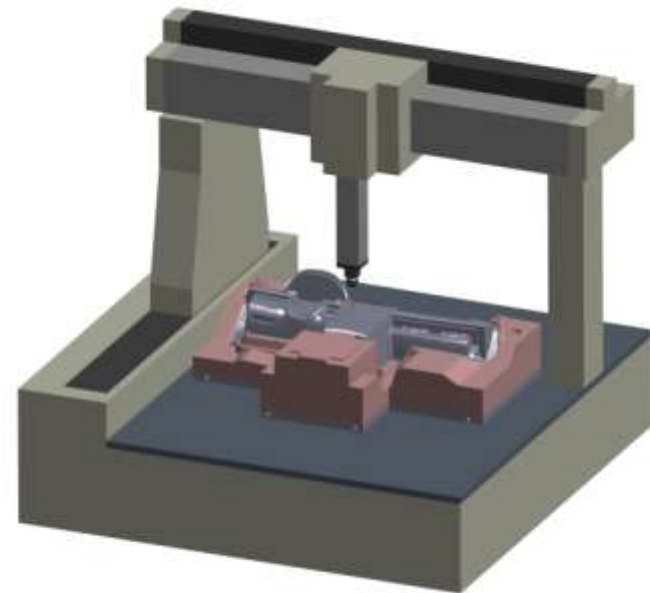
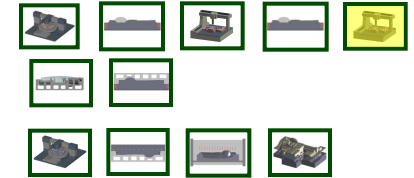

BUILD SUPPORT FRAME

- The support frame is used to support the silicone negative over the master model.
- It is offset from the model, and CNC machined or laid-up off of the master model.

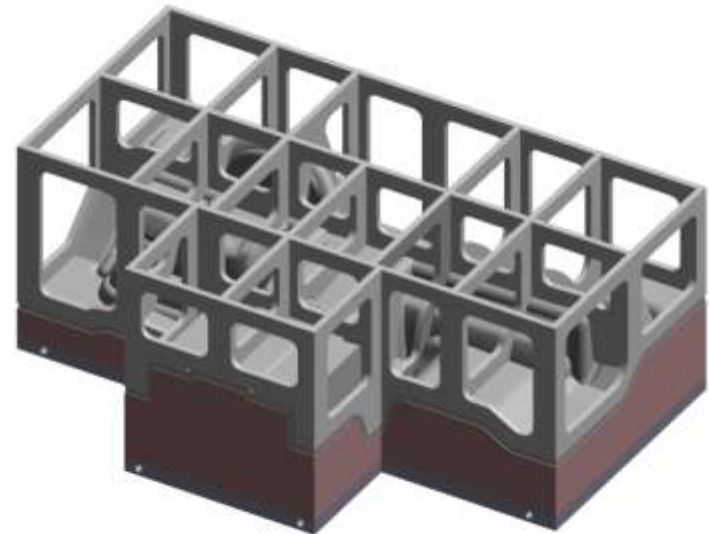
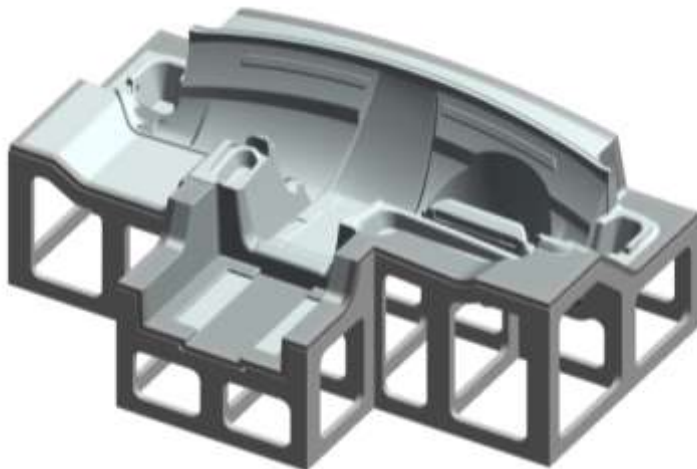
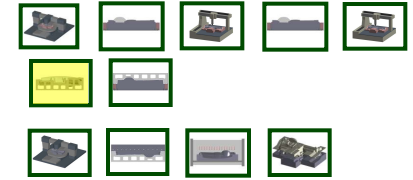

SILICONE NEGATIVE

- Silicon is cast between the support and the master model
- The silicone negative is used to transfer the texture from the master model onto the mandrel.

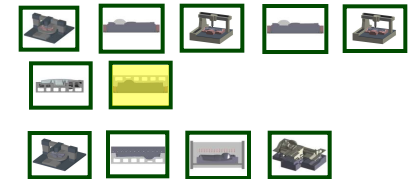

SILICONE NEGATIVE

SUPPORT FRAME

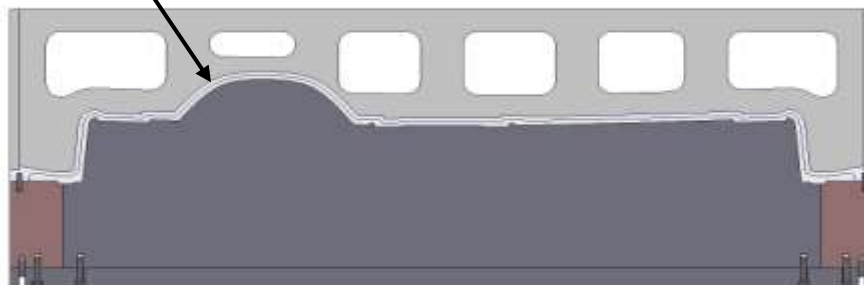

MASTER MODEL

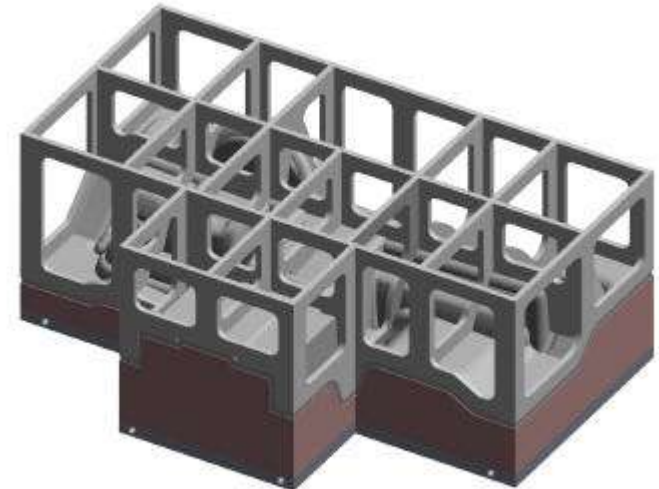

CNC MACHINE STEEL MULTI-PIECE MANDREL

- Multi-piece steel mandrel is CNC machined to CAD data
- Data is offset 1.5 mm smaller to provide for silicone skin
- Mandrel is manufactured simultaneously with the master model.

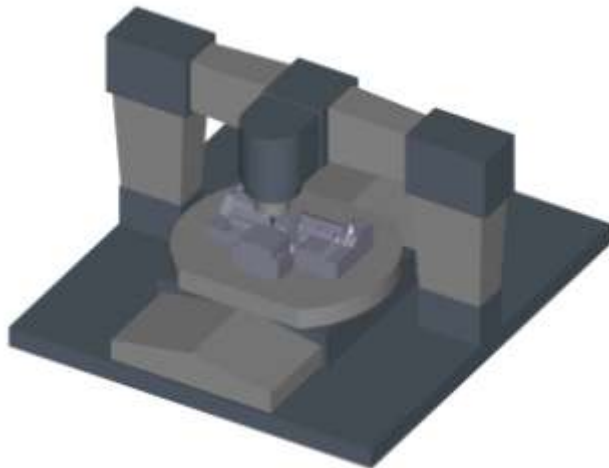
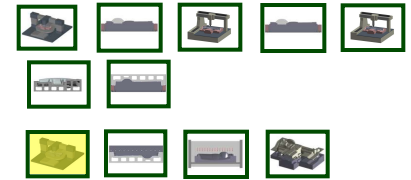

CAST SILICONE ONTO MANDREL

- The mandrel is positioned onto the support frame.
- 1.5 mm of silicone is cast between the mandrel and the silicone negative.
- The texture from the silicone negative is exactly replicated onto the mandrel.

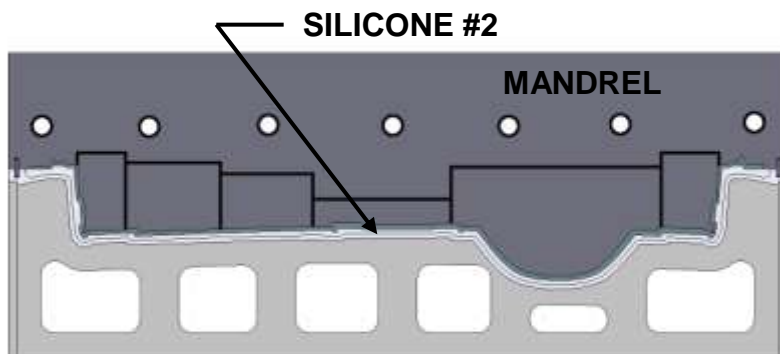
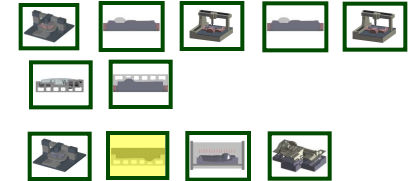

SUPPORT FRAME

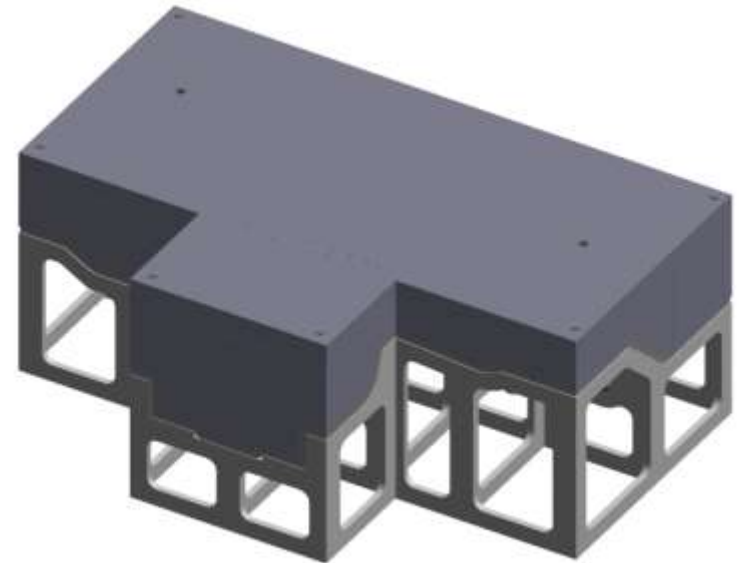

NICKEL VAPOUR DEPOSITION

- The mandrel is placed in the deposition chamber and heated to approximately 180 C.
- Nickel is deposited onto the mandrel at a rate of 0.25 mm/hr
- Mandrel must be cleaned and prepared prior to each deposition.

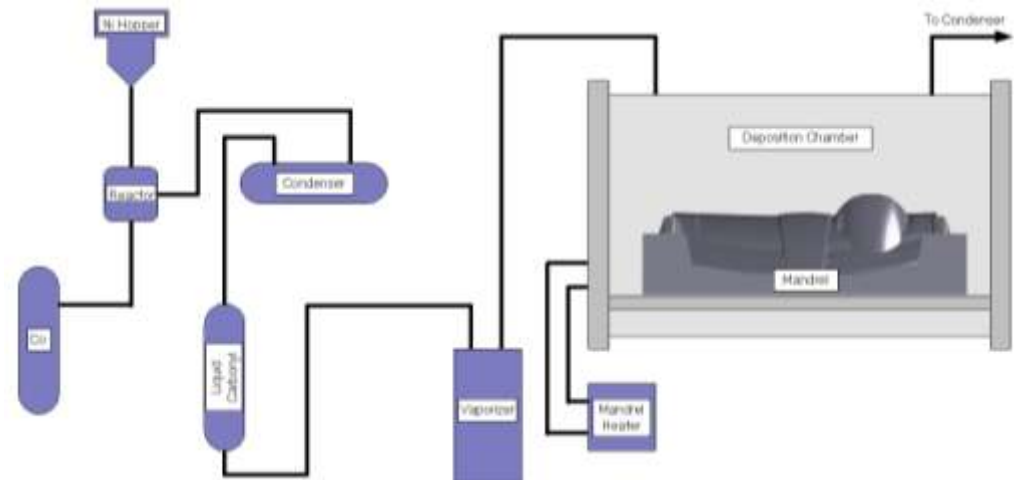
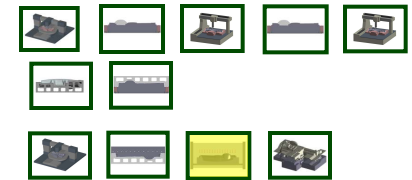

SHELL STRIPPING

- Proprietary mandrel carefully stripped from the nickel shell.
- The mandrel is cleaned and prepared for subsequent nickel depositions.
- The shell proceeds to mold build.

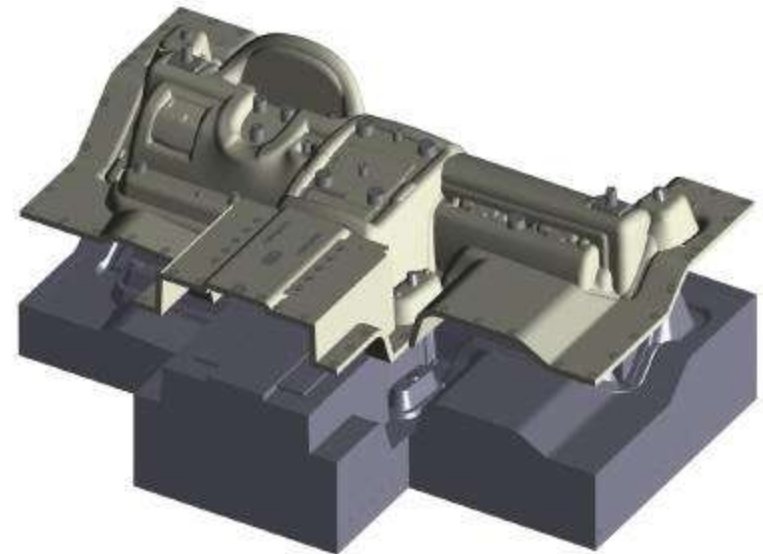
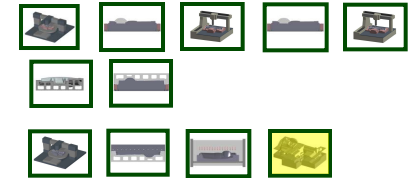

New Developments



LEATHER WRAPPED
MODELS TO EPOXY
MASTER MODELS (MAZDA
PROGRAM)



NEGATIVE VACUUM
FORMING AND IN-MOLD
GRAINING PROJECTS
(BMW ARMREST)



6

NVD Operations

Concept

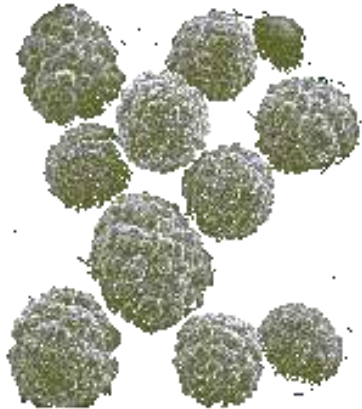

Nickel Powder

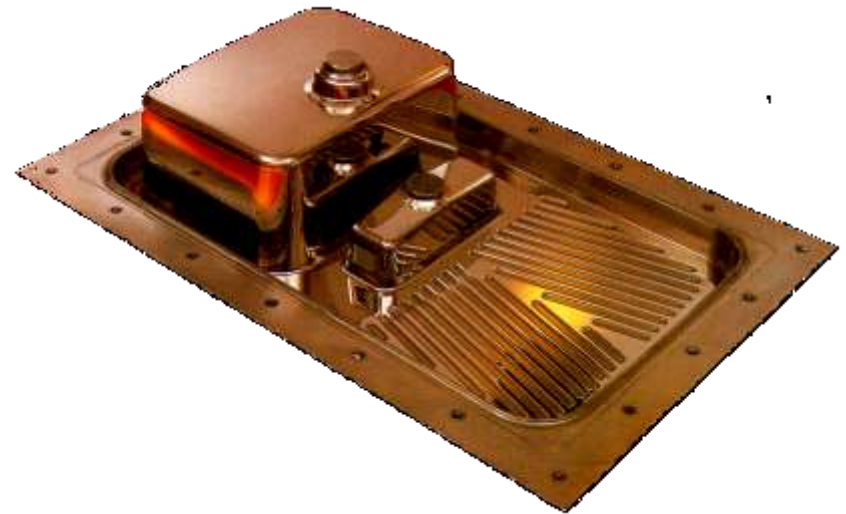

Solid Nickel Shape

Chemical Process

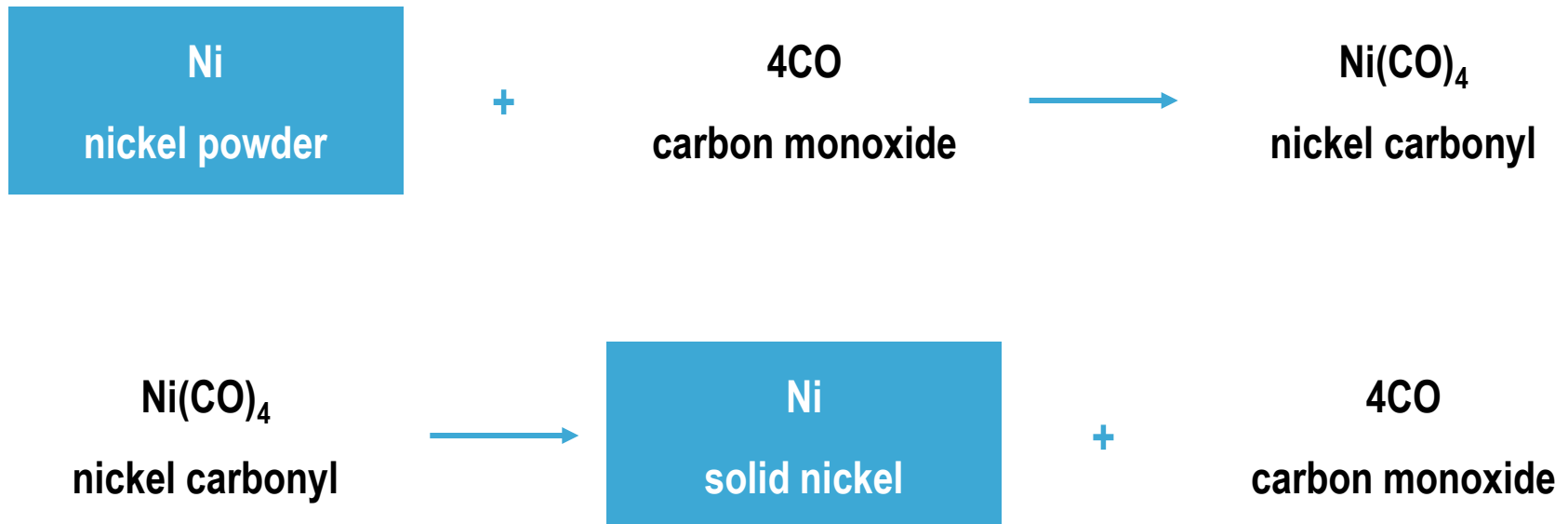

Main Processing Steps of NVD Technology

1. Carbonyl Generation
2. Carbonyl Evaporation & Nickel Deposition
3. Environmental Control System



Carbonyl Generation

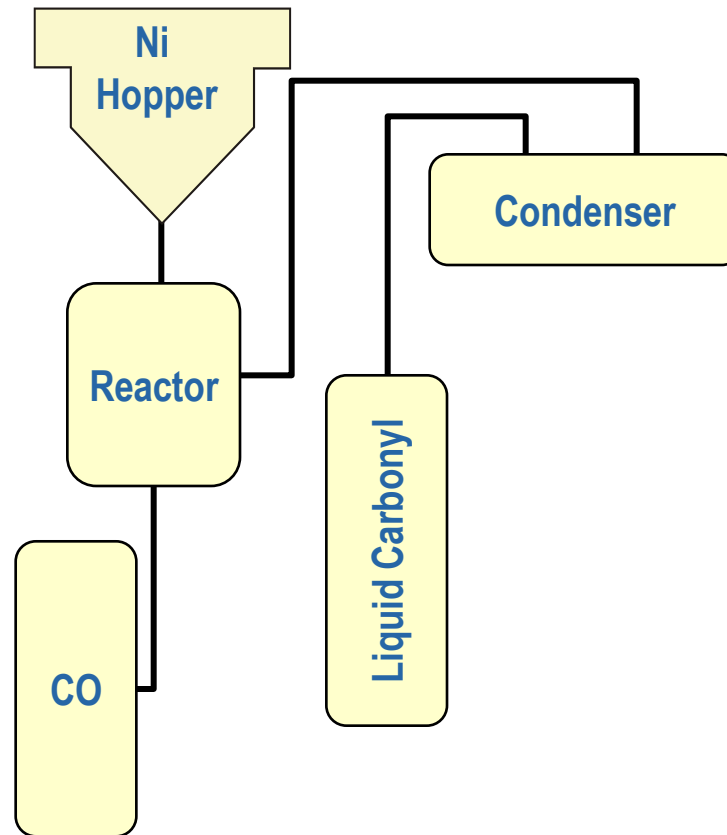

Carbonyl Evaporation & Nickel Deposition

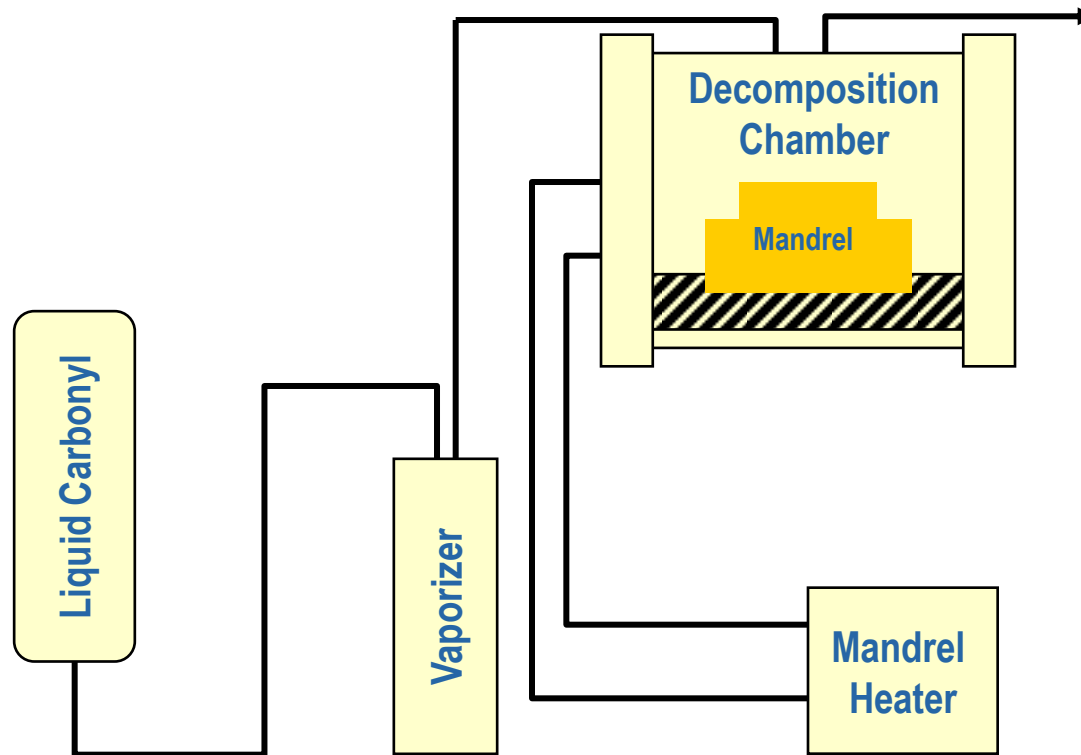

Environmental Control System

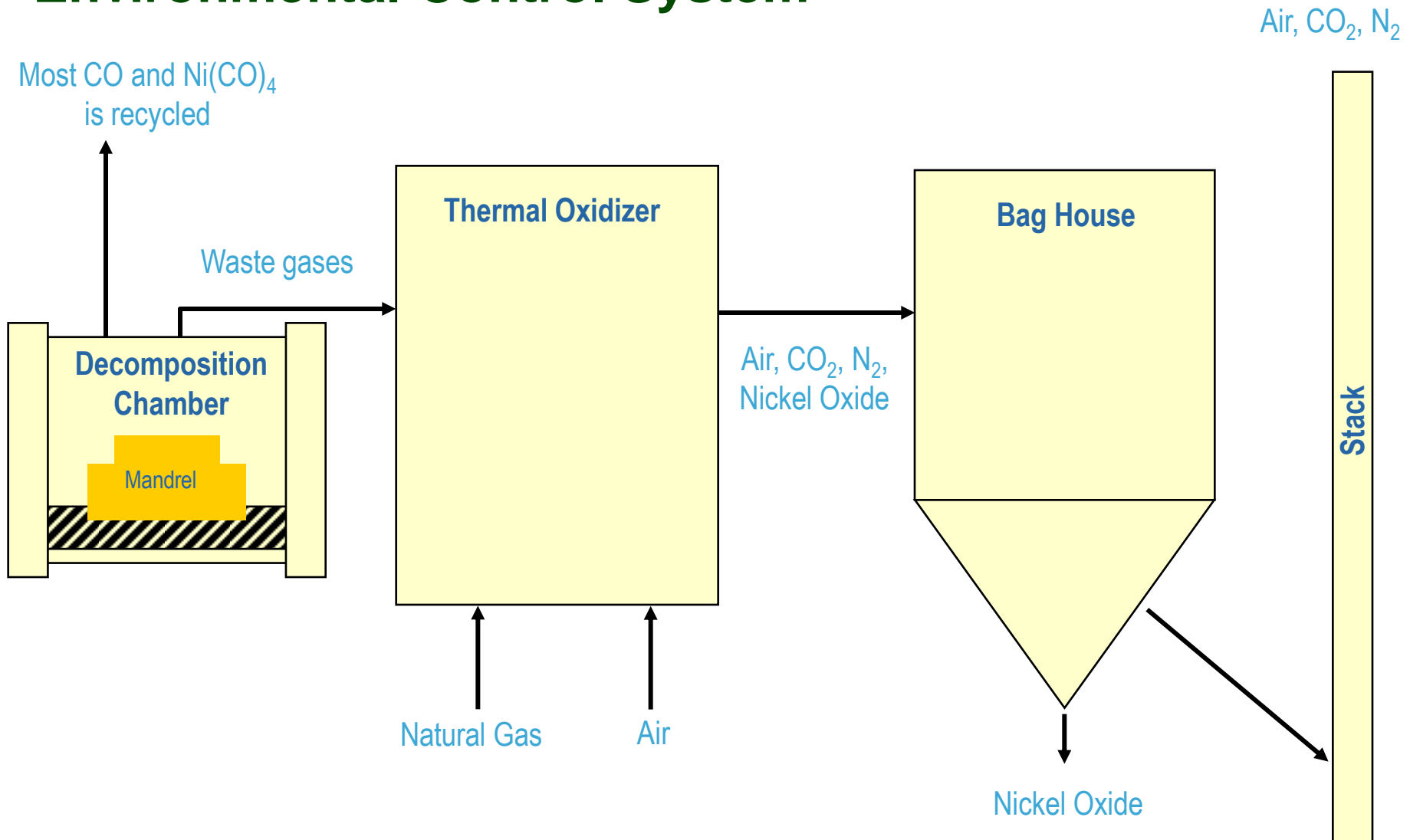

Deposition Methods

- In-chamber Deposition

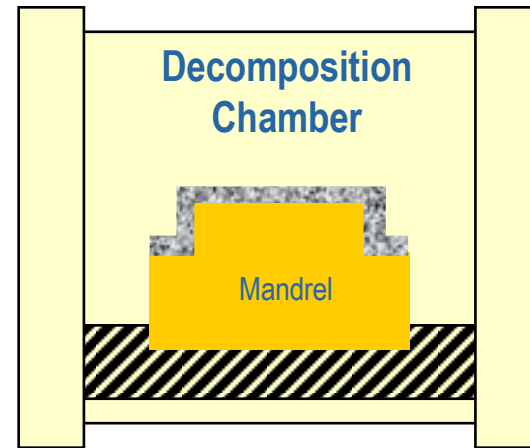

- Hollow Deposition

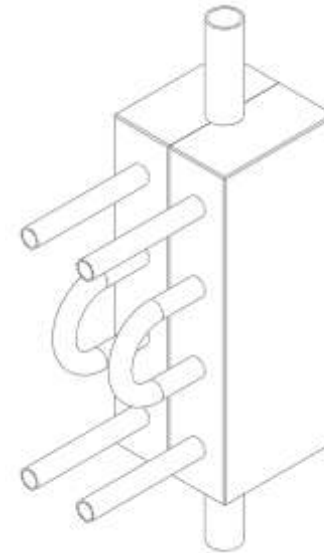

In-Chamber Deposition

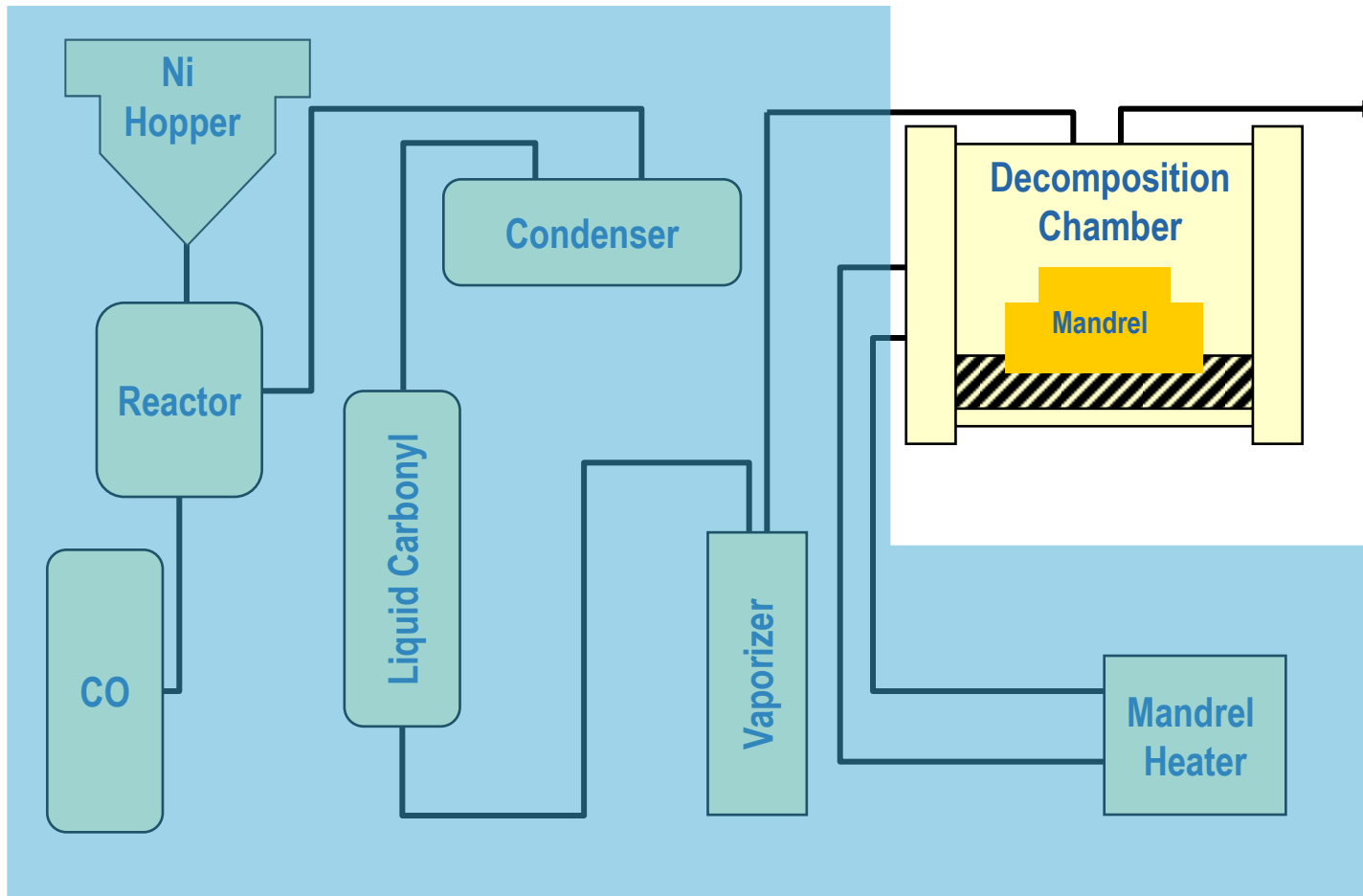

In-Chamber Deposition

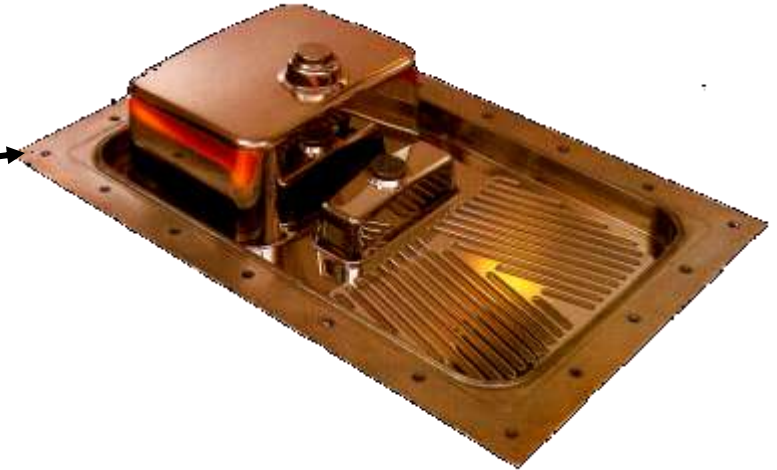
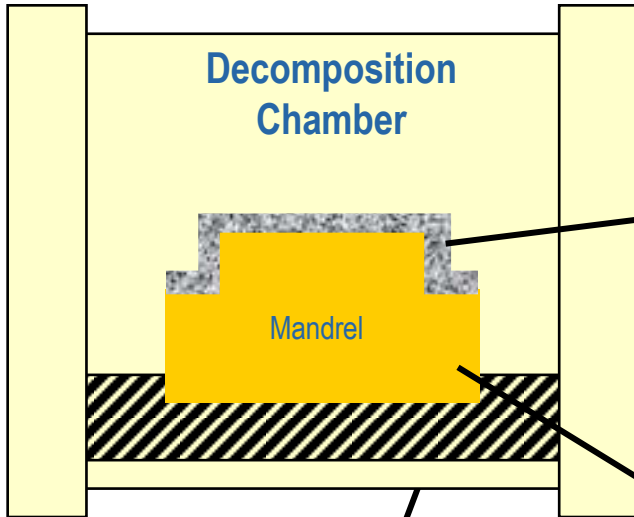

NVD Material

- It is a very pure material (99.99% nickel)
- It is very corrosion resistant
- Very high thermal conductivity (2.5 times higher than tool steel)
- It can be very ductile, comparable to aluminum
- It welds extremely well (sulfur free, unlike electroformed nickel)
- Virtually a stress-free material (unlike electroformed nickel)
- Very uniform deposition thickness (better than electroformed nickel)
- Very good mold release properties

NVD Nickel Shell



1. 25mm per 100 hr deposition rate
2. Uniform thickness & temperature
3. Negligible residual stress
4. Cavities made sequentially from the same mandrel
5. Little variation from cavity to cavity
6. Replace damaged shell in 3 weeks
7. Hollow deposition possible in many cases
8. 0.999 pure Ni – weldable and no de-lamination
9. No environmental impact (closed system)

Electroformed Ni Shell



1. 25mm per 2000 hr deposition rate
2. Shell thickness is not uniform
3. Inherent residual stresses
4. Cavities made simultaneously from different mandrels
5. Problematic variation from cavity to cavity
6. Replace damaged shell in 16-30 weeks
7. Cannot do hollow
8. Sulfates contamination from electroplating bath – difficult welding + de-lamination risk

NVD Product Development – Aerospace Components

- Weber is currently developing procedures to deposit nickel on nozzle components and create solid nickel shell components



NVD Product Development – Fuel Injectors

- Weber is developing procedures to coat fuel injectors. This is a development project to reduce gas emission in trucks.
- Application is for large truck engines with initial expected use of 1 million injectors per year



NVD Product Development – Nickel Coated Particles

- NVD is one of the few processes capable of coating particulates.
- NVD appears to be very cost effective for this process.
- Weber is currently making samples of the materials
- Current uses for coated powder include:
 - Cutting tools;
 - Abrasives;
 - EMI shielding/fire retardant;

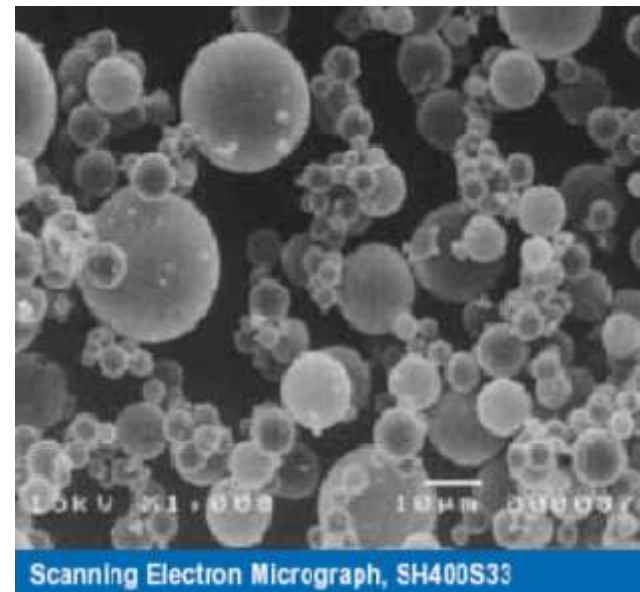

4

Other Applications
Home & Building
Products



Injection & Compression Molds

- Using Weber's exclusive Nickel Grain Technology, authentic textures and grains can be reproduced using Compression Molding processes.

Compression – Home & Building



**COMPRESSION MOLDS FOR RESIDENTIAL FIBERGLASS
ENTRY DOORS WITH AUTHENTIC REPLICATION OF
WOOD GRAIN.
CUSTOMER: THERMA TRU DOORS**

Injection – Home & Building

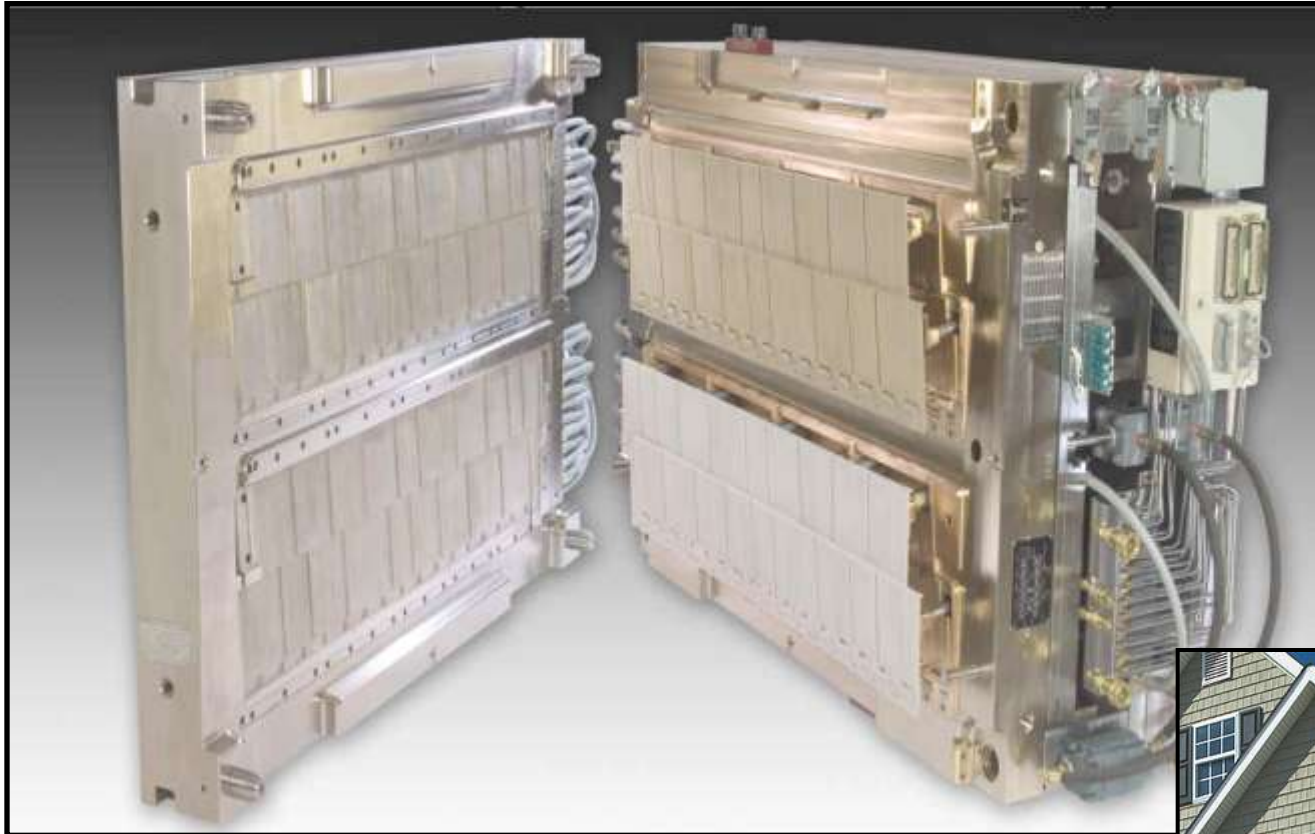

2 CAVITY MOLD FOR RESIDENTIAL ROUGH SAWN SIDING; CUSTOMER NAILITE.



Home & Building – Composite Product Development



Home & Building – Product Development



Development of Compression Molds for an Authentic Rustic Outdoor Table using NVD nickel shells

Development of Compression Molds for Authentic Cedar Shake Siding Panels using NVD nickel shells



5

Other Applications
For NVD Nickel Shells

Home & Building – Shells for Sink Molds

- NVD Nickel Shells for composite kitchen sinks (eg. Granite filled PMMA)
- Excellent mold release
- Excellent uniformity>uniform mold face temperatures
- Durable, fast, accurate>within 0.005in to CAD data
- NVD shell molds replaced aluminum production tools for Dupont and Villeroy Boch with significant cost savings.



NVD Shells – Injection/Compression Molding



- Kitchen Sink & Bathtub Products - Molded with NVD shells
- Dupont Sink production cycle cut in half (*Moldmaking Tech. Magazine, October 2004*)

Automotive – Low Pressure Composite Parts

- Large parts using low pressure processes have utilized NVD tooling
- Developments in materials and processes such as Resin Infusion, Autoclave and RTM will take good advantage of NVD tooling



Automotive

Larger Resin Transfer Mold (RTM)



Complete Nickel Shell Mold



Extended Roof on MAN Truck

MAN Truck Roof Manufactured
By Fritzmeier Composites



*Received Innovation Award for
Best
Industrial Application 2000*



Assembly of Nickel Shell to Mold Base

Aerospace Tooling – Wide Range of Materials



- NVD Nickel Shell Tools
- Less costly than Invar
- Approx. same cost as Steel, far less costs for rate tools
- More durable and accurate than High Density Foam or Reinforced Epoxy
- More durable than Aluminum



Nickel Shell Molds – Airbus – Encapsulated Heating Lines

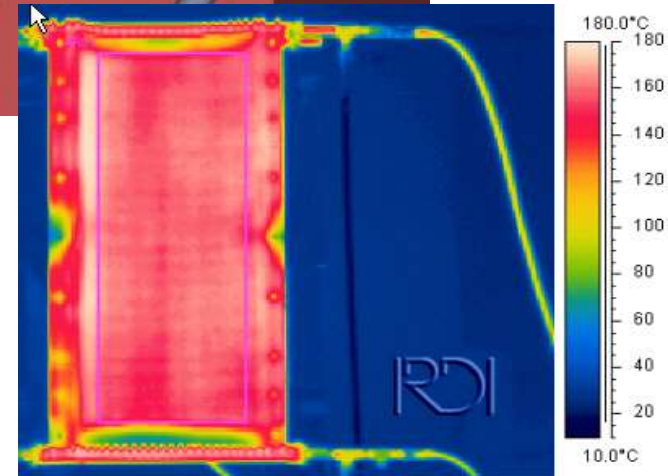
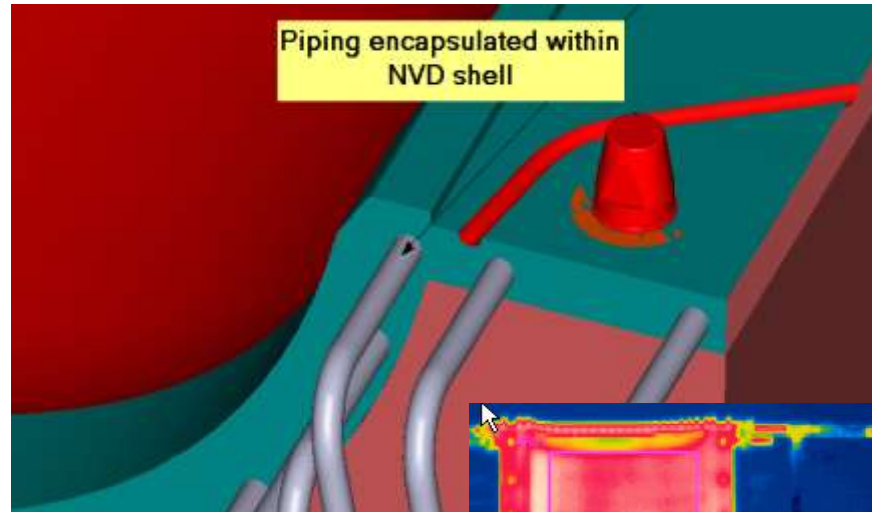

Nickel Shell Mold with Encapsulated heating line technology - 25 % cycle time reduction by changing 140C (250F) in 1 minute on a 10mm thick NVD shell.

HEAD OFFICE

16566 Highway 12
P.O. Box 399
Midland, ON L4R 4L1 CANADA



Robert Sheppard
Vice President

Direct: (705) 527 - 2976
Mobile: (705) 527 - 2123
Email: rob.sheppard@webermfg.ca

Tel: (705) 526-7896 [Main]
Fax: (705) 526-3818
Web Page: <http://www.webermfg.ca>



Alan Gobien
Business Manager
Automotive Interiors

Direct: (705) 527 - 2950
Mobile: (705) 427 - 3600
Email: alan.gobien@webermfg.ca



Bernie Koolwick
US Sales

Direct: (248) 338 - 4440
Mobile: (248) 343 - 3245
Email: bernie.koolwick@webermfg.ca

A large, 3D-rendered question mark in a dark green color. It has a thick, rounded stem and a curved top. The question mark is positioned on the left side of the slide, casting a soft shadow on the light green background. To its right, there is a large, faint, semi-transparent question mark that serves as a background element.

Questions?