

FEASIBILITY OF CONTINUOUS-FIBER REINFORCED THERMOPLASTIC TAILORED BLANKS FOR AUTOMOTIVE APPLICATIONS

A. Burkhart and D. Cramer
Fiberforge

Abstract

Recent developments in the rapid processing of continuous-fiber reinforced thermoplastics (CFRTP) offer a method for automakers and suppliers to manufacture high-performance structures that meet automotive cost, performance, and volume requirements. Benefits of thermoplastic composites include rapid processing, high toughness, ease of recycling, long shelf life, and multi-stage processing. CFRTP tailored blanks are flat, net-shape preforms comprising aligned, continuous reinforcing fibers in a thermoplastic matrix. These tailored blanks can vary in thickness, fiber orientation, material composition, and shape based on part requirements. Main benefits include material efficiency, low scrap, and low weight. This paper investigates the feasibility of stamp forming CFRTP tailored blanks. Experimental results are presented showing effects of forming on consolidated tailored blanks and the potential for a high quality surface finish.

Background

Fiberforge has developed a novel automated process for fabricating thermoplastic composite parts. This process, illustrated in Figure 1, begins with the creation of "tailored blanks", which are flat, net-shape preforms comprising continuous-fiber reinforced thermoplastics (CFRTP). Tailored blanks can vary in thickness, fiber orientation, composition, and shape based on the needs of the part. These blanks are fabricated using automated machinery designed for high throughput while maintaining precise fiber alignment. Once created, tailored blanks are consolidated and thermoformed into their final shapes. Thermoforming CFRTP provides a means for reducing cycle time to one minute or less while maintaining high mechanical performance. The primary benefits of fabricating parts with tailored blanks are rapid processing, high material efficiency, low scrap, and excellent mechanical properties. Tailored blanks have seen interest by major automotive manufacturers, and have been used to form automotive components, including the seat back frame shown in Figure 1.

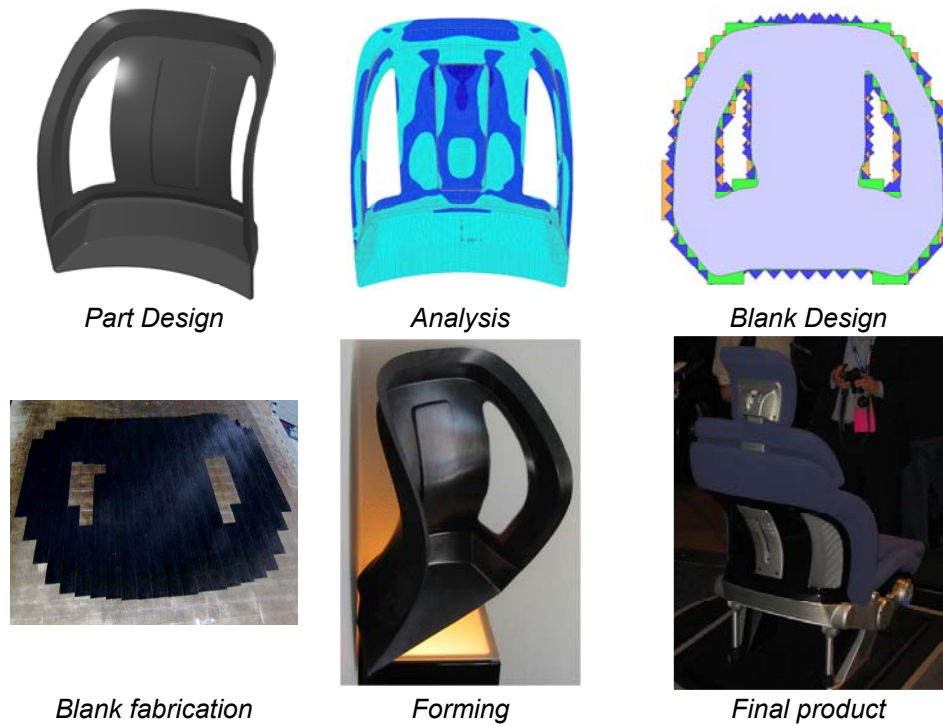

Figure 1. Steps for creating a component using tailored blanks. Consolidation (not shown) occurs between blank fabrication and forming.

Material Efficiency

Tailored blanks are semi-finished sheet goods that have design flexibility similar to hand laid-up composites. By analyzing the part to be created, material can be placed only where needed and in the orientation necessary for structural integrity. Mechanical properties of a hand laid-up composite can be optimized for complex loading, but the hand layup process is not viable for high-volume automotive applications. With tailored blanks, high-volume production can be achieved while still maintaining benefits of hand layup—a combination unmatched in thermoplastic composites. As an example of tailored blanks designed specifically to reduce scrap, net-shape and near net-shape blanks were fabricated for forming a hemisphere, as shown in Figure 2. Tabs were added to one of the blanks to accommodate blank holder clamps. Careful pattern design has been shown to reduce scrap in composite thermoforming by 50–60%.

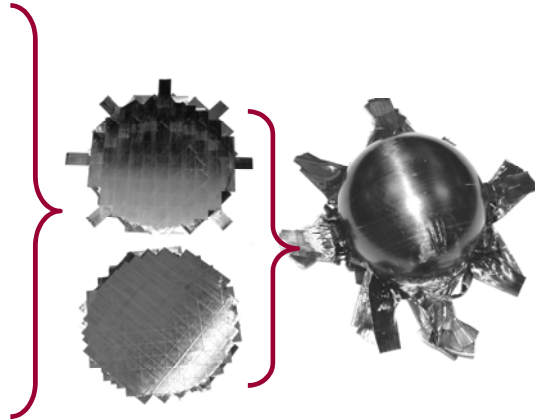

Figure 2. Tailored blanks designed for forming hemispheres with minimal scrap. Clamping tabs were designed into one of the blanks to accommodate an in-house blank holder.

High Volume Capability

Automated processing and short cycle times are advantages of using tailored blanks for high-volume applications. The automated layup system (ALS) has successfully fabricated tailored blanks at speeds up to 1350 mm/s. Higher speeds lead to less interply consolidation, but this has not been of primary concern, since the blanks are consolidated following layup. Further process development will utilize raw materials (fiber and bulk polymer) directly, which will require an intermediate consolidation step to maintain rapid cycle times. Impregnation of fibers by a viscous thermoplastic is best performed in bulk rather than during layup to minimize overall cycle time.

Materials

To date, tailored blanks have been fabricated with thermoplastic composite materials ranging in performance from glass/PP to carbon/PEEK and carbon/PEI, thus demonstrating the flexibility of the manufacturing equipment to process the full spectrum of thermoplastic matrix composite materials. For this study, polyamide (PA) was chosen as the matrix constituent of the composite because it shows promise for automotive applications due to a favorable price-to-performance ratio.

Economics

Cost is at the forefront of product development and production, particularly in the automotive industry. Traditionally, advanced composites have been expensive and slow to manufacture. Yet, success with bulk molding compound (BMC), sheet molding compound (SMC), and long-fiber reinforced thermoplastic (LFRT) has proven that composites can be competitive in the automotive sector. However, BMC, SMC, and LFRT lack the necessary strength and stiffness required to replace metals in many structural applications. The automotive industry is only beginning to incorporate high-performance CFRT into structural components, and the primary barrier to more widespread use has been cost. An economic study of a spare wheel well by Wakeman *et al.* (1) concluded that for high-volume applications, carbon/PA and carbon/glass/PA hybrid tailored blanks significantly improved cost-effectiveness compared with existing composite sheet materials while still achieving 50% weight savings. In this study, manufacturing the spare wheel well with carbon/PA tailored blanks would save 50–75% of the

scrap compared with existing composite sheet goods while reducing the overall part cost by 30%. Glass/PA tailored blanks were shown to be 20% less costly to produce, and carbon/glass hybrid blanks were shown to be 29% less costly than hybrid sheet goods.

Demonstrated Fabrication Process

For this study, 200-mm diameter hemispheres were formed with tailored blanks. Mechanical performance of the formed parts was then compared with flat-blank specimens. Additionally, tailored blanks with resin-rich surfaces were fabricated to improve surface finish of the formed parts. Results of this investigation are also presented.

Tailored Blank Fabrication

At the core of tailored blank fabrication is the automated layup system (ALS), which includes a motion table with three degrees of freedom (two linear and one rotational), and a layup head that feeds, heats, and places non-overlapping strips of material on the motion table to create a ply. The ALS forms a laminate by placing successive plies on top of previously-laid plies. Any two-dimensional pattern that fits within the geometric constraints of the system can be created including those with holes, variable thickness, and any laminate orientation.

Tailored blanks for the current study were designed such that test specimens could be cut from the blanks following consolidation. Square cross-ply blanks were laid up in the ALS at 300 mm/s, 500 mm/s, and 1000 mm/s using pre-impregnated AS4/PA6 tape. Cross-ply laminates have been found to produce quality hemispheres using spring-tensioned fixturing. The 14-ply blanks were laid-up with a laminate configuration of $[(0/90)_3/0]_S$, and without significant changes in process parameters other than layup speed. Visual inspection indicated that the degree of “off-the-table” consolidation decreased as lay-up speed increased.

Consolidation

To obtain maximum mechanical properties, tailored blanks were consolidated prior to forming. This was accomplished with heated flat platens in a 408 metric ton press using a consolidation mold comprising a two-piece silicone dam and two stainless steel caul plates. Consolidation parameters varied only slightly between blanks, primarily due to temperature control of the platens. Pressures suitable for consolidation range from 3 MPa to 10 MPa, and common consolidation temperatures of carbon/PA6 tailored blanks range from 220°C to 260°C. Generally, low temperatures and pressures require more time than higher temperatures and pressures to consolidate blanks. However, higher temperatures increase the possibility of thermal degradation of the polymer, and a combination of higher pressures and temperatures increases fiber movement.

Blanks were thermocoupled at opposite corners to measure blank temperature and allow manual fine-tuning of temperature setpoints. After the consolidation tool reached the desired temperature, blanks were inserted into the press, pressure was applied, and after a short dwell period the platens were quenched with a water/air mixture. The consolidated blanks were removed when the thermocouple readings decreased to 130°C.

Forming

Rapid forming is an important benefit of CFRTP, and may be performed using a variety of techniques, including diaphragm forming, hydroforming, matched-die forming, and rubber-die molding (2). In this study, tailored blanks were formed into hemispheres with a matched-die mold illustrated in Figure 3.

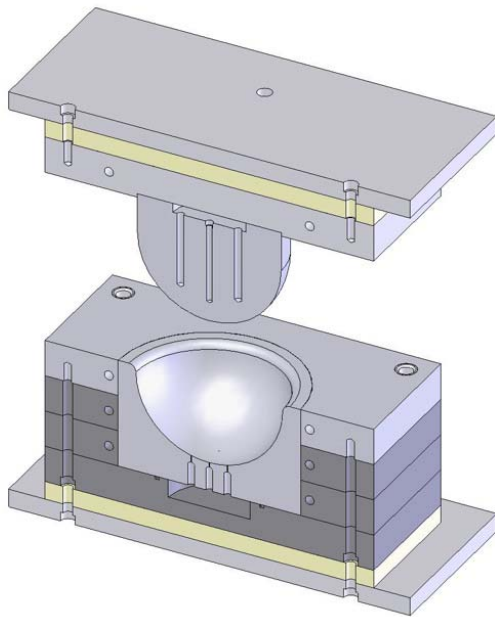

Figure 3: Section illustration of matched-die hemisphere mold used for forming.

Proper blank fixturing is a critical component of thermoforming tailored blanks, since the continuous, aligned fibers are inextensible compared with the viscous polymer. Without proper fixturing, wrinkling can occur during forming due to shearing (3) or longitudinal fiber compression. Parts with simple, large radius curves and a small deformation gradient in the through-the-thickness direction can be draped in a mold without fixturing. However, complex shapes, such as those with corners, compound curvature, or highly varied geometry, require blank edges to be restrained.

For this study, a blank holder was attached to the shuttle system on the thermoforming press. It included mechanical clamps fastened to springs that were connected under tension to a metal frame. This fixturing arrangement allowed for easy tuning of blank tension, tension directions, and clamping locations. For hemispheres formed in this study, eight clamps were used. A slip ring or similar arrangement that restrains the entire blank perimeter may offer additional benefits over tensioned springs, and will be considered in future studies.

After being attached to the fixture in the loading station, blanks were shuttled into an infrared (IR) oven. Blank sag was used to trigger transfer into the press, where the blanks were non-isothermally formed. Mold temperatures between 160°C and 180°C were used with 60–90 second dwell times. Forming pressure was significantly higher than consolidation pressure, but well within the limits of the press and tooling.

Testing

Short beam shear testing is commonly used as a quality control test for reasons of speed, cost, and small specimen size. Short beam shear test specimens were cut from both consolidated blanks and formed hemispheres in both 0° and 90° principal material directions. Testing was performed using a short beam shear test fixture mounted in an Instron 4400 test frame. ASTM D 2344-84 (Apparent Interlaminar Shear Strength...) was referenced for testing, although deviation from the method was necessary due to specimen geometry. The test standard allows for curved (ring) specimens to be tested, but does not include specimens with compound curvature (hemisphere specimens). Also, the short beam shear test applies a three-point load to a specimen, with a specified span-to-thickness ratio of 4. This low aspect ratio promotes shear failure and reduces bending stresses in the specimen (4). Actual aspect ratios in this study ranged from 7 to 9, which exceed that listed in the standard. As the aspect ratio of a test specimen increases, bending stresses constitute a larger portion of the overall stress state, and increase the possibility of bending (tensile) failure. An examination of tested samples revealed multiple failure modes, indicating the presence of a combined stress state with significant shear and bending stress components. Since both bending and shear failures were observed, and because specimens with larger-than-specified aspect ratios were tested, both the apparent interlaminar shear strength and then three point bending strength (tensile strength) were calculated for each specimen.

Apparent interlaminar shear strengths and tensile strengths of consolidated blanks fabricated at different layup speeds were compared, but no correlation was found between layup speed and consolidated blank strength. This indicates that the consolidation level of tailored blanks directly following layup is unimportant, as the consolidation step “equalizes” consolidation levels of tailored blanks fabricated at different speeds

Tables I and II compare strengths of specimens cut from hemispheres and from flat consolidated blanks. Calculated apparent interlaminar shear strength is shown in Table I and calculated tensile strength is shown in Table II. Hemisphere specimens had higher strengths in all cases except for tensile stress in the 0° direction. Differences in strengths may be due to geometric differences between flat consolidated blank specimens and compound curvature hemisphere specimens. Higher hemisphere strengths may be due to reduced void content in the formed parts compared with the flat-blank parts. The lower hemisphere tensile strength in the 0° direction may be a result of de-consolidation during forming.

Table I. Comparison of apparent interlaminar shear strength between consolidated blanks and formed hemispheres for 0° and 90° orientations.

	Apparent Interlaminar Shear Strength [MPa]					
	0°			90°		
Blank ID	Consolidated		%	Consolidated		%
	Blank	Hemisphere	Change	Blank	Hemisphere	Change
J	50.4	56.7	12.33	33.2	39.0	17.56
L	45.9	44.0	-4.30	37.7	41.4	9.88
M	49.7	44.9	-9.70	46.1	47.4	2.90
O	51.1	52.0	1.77	37.8	38.9	2.71
Average	49.3	49.4	0.02	38.7	41.7	8.26

Table II. Comparison of tensile strength between consolidated blanks and formed hemispheres for 0° and 90° orientations.

Blank ID	Tensile Strength [MPa]					
	0°			90°		
	Consolidated Blank	Hemisphere	% Change	Consolidated Blank	Hemisphere	% Change
J	890.8	965.4	8.38	574.5	678.9	18.18
L	778.9	732.8	-5.91	628.3	688.2	9.54
M	820.8	743.9	-9.37	774.2	768.6	-0.72
O	828.3	772.1	-6.78	582.8	604.2	3.67
Average	830	804	-3.42	640	685	7.66

Surface Modification

Many automotive applications require products that have aesthetic appeal in addition to being economical, durable, and able to withstand in-service loading. Initial studies of hemispheres formed with tailored blanks did not produce class-A surfaces due to dry areas, fiber movement, and minor fiber misalignment. Two techniques for improving the aesthetic surface of thermoformed tailored blanks are fabricating blanks with a resin-rich surface and applying a surface veil to mask underlying fiber orientation.

To investigate the potential of surface modified tailored blanks, carbon/PA6 hemisphere blanks were fabricated as previously described. Prior to consolidation, blanks were given a surface treatment of either 0.075-mm PA6 film or a combination of 6.8-g/m² carbon veil with 0.075-mm PA6 film. The blanks were consolidated as described previously with no process variation to compensate for the addition of the surface modification. Wetting the veil with PA6 was assumed to be accomplished during consolidation since the veil fiber volume was low. Following consolidation, tailored blank cross section microscopy specimens were examined. Figure 4 shows the two surface treatments. Compared with an unmodified sample, the surface modifications are clearly visible. The specimen with the PA6 surface film added allowed fiber migration toward the surface of the blank, whereas the addition of a veil restricted fibers from moving toward the surface.

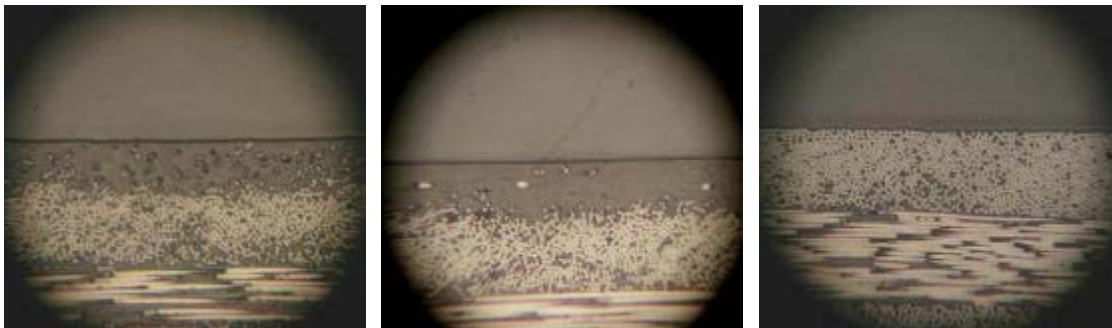

Figure 4. Cross section micrographs of three consolidated blank specimens: PA6 film added to the surface (left), PA6 film and veil added to the surface (center), and no surface modification (right).

Following investigation of the unformed specimens, the blanks were non-isothermally formed into hemispheres and examined. Both surface modifications showed promise. The additional resin ply in both cases produced a more lustrous finish. However, with the overall improvement in surface finish, mold imperfections became more apparent. The surface veil did not completely mask the oriented fibers in the blank, but a heavier veil or multiple plies of the same veil would produce an aesthetic composite.

Microscopy specimens were cut from the formed hemispheres to assess the effects of surface modification on fiber location through-the-thickness. Figure 5 shows that both surface modifications applied prior to the consolidation step remained in place to produce thermoformed composite parts with a good surface finish.

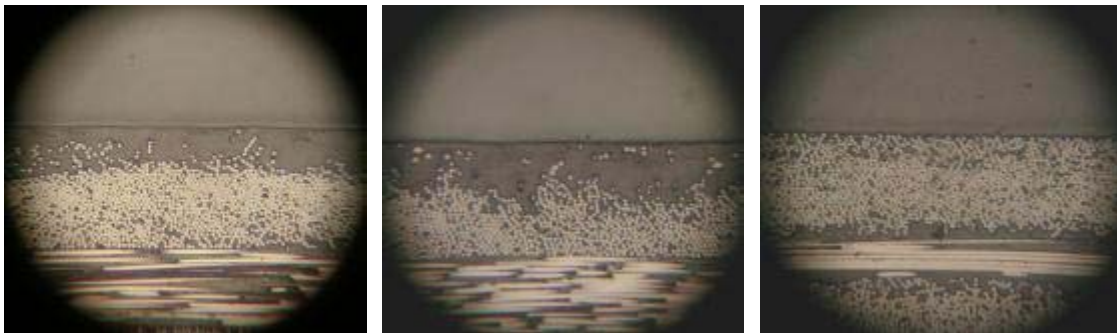

Figure 5. Cross section micrographs of three hemisphere specimens: PA6 film added to the surface (left), PA6 film and veil added to the surface (middle), and no surface modification (right).

Each surface improvement method requires only minimal additional material cost and labor. However, the surface modifications reduced overall material strength, as shown in Tables III and IV, due to an increase in cross sectional area without additional reinforcing fibers. All calculated strengths decreased in both 0° and 90° directions for specimens taken from consolidated blanks and hemispheres with surface improvements. For two parts with similar strength and stiffness, the part with a surface modification will have a slightly higher mass. Thus, there is a small tradeoff between mechanical properties and surface finish.

Table III. Comparison of shear strengths of consolidated blanks and formed hemispheres with and without surface modifications.

	Apparent Interlaminar Shear Strength [MPa]			
	0° Blank	90° Blank	0° Hemisphere	90° Hemisphere
Surface Modification	48.5	37.7	48.0	40.1
No Surface Modification	51.1	40.6	50.8	43.2
% Difference	-4.9	-7.0	-5.5	-7.1

Table IV. Comparison of tensile strengths of consolidated blanks and formed hemispheres with and without surface modifications.

	Tensile Strength [MPa]			
	0° Blank	90° Blank	0° Hemisphere	90° Hemisphere
Surface Modification	804	606	752	646
No Surface Modification	861	684	855	724
% Difference	-6.6	-11.5	-12.0	-10.7

Conclusion

Tailored blanks have been shown to produce structural CFRTTP components that could reduce vehicle weight, improve fuel economy, and reduce part count. Material efficiency of these thermoplastic composites allows a very stiff, strong, and lightweight component to be fabricated with minimal associated scrap. A study of the economic feasibility of using tailored blanks for an automotive component has shown that structural composites can be used in high volume applications. Formed tailored blanks retain, and, in some cases improve, the interlaminar shear strength and tensile strength of consolidated blanks. Surface finish improvements using a resin-rich surface layer with or without a veil show promise in producing structural composites with excellent appearance.

References

1. Wakeman, M.D., Cramer, D.R., Manson, J.E., "Technical Cost Modeling of an Automated Net-Shape Preforming Process for Thermoplastic Composites: A Case Study", *Proceedings of the 26th SAMPE Europe International Conference*, Paris, France, (April, 2005).
2. Bhattacharyya, D., ed., Composite Sheet Forming, Elsevier Science B.V., Amsterdam, The Netherlands, (1997).
3. Advani, S.G. and E.M. Sozer, Process Modeling in Composites Manufacturing, Marcel Dekker, Inc., NY, (2003).
4. Adams, D.F., L.A. Carlsson, and R.B. Pipes, Experimental Characterization of Advanced Composite Materials, 3rd ed., CRC Press LLC, U.S.A, (2003).